

<b>Project</b>	Ventura College - Applied Science Center	<b>Date</b>	July 26, 2013
<b>Project Location</b>	4667 Telegraph Road Ventura CA 93003	<b>Architect's Project Number</b>	05.8010.000
<b>Owner / Client</b>	Ventura County Community College District	<b>File</b>	6A <b>This is page</b> 1 of 3
<b>To</b>	Heery International	<b>Attention</b>	Rich Magill
<b>Address</b>	103 Durley Ave.		
<b>City</b>	Camarillo	<b>State</b>	CA <b>Zip Code</b> 93010
<b>Delivered via:</b>	<input type="checkbox"/> <b>Messenger</b>	<input type="checkbox"/> <b>Hand carried</b>	<input type="checkbox"/> <b>Facsimile</b>
	<input type="checkbox"/> <b>Express</b>	<input type="checkbox"/> <b>Pick-up</b>	<input checked="" type="checkbox"/> <b>E-mail Address</b>
	<input type="checkbox"/> <b>Mail</b>	<input type="checkbox"/> <b>UPS</b>	<input type="checkbox"/> <b>Website Address</b>

This Addendum will become part of the Contract Documents. The Contractor shall promptly inform subcontractors and all others performing or supplying any of the Work of all relevant contents of this Addendum. In case of conflicting provisions with previous addenda or communications, provisions in this Addendum supersede only those conflicting issues. It is the responsibility of the Contractor to notify all subcontractors from whom it accepts bids of all changes in the drawings and specifications covering this project. Receipt shall be acknowledged by inserting the addendum number and its date in the bid form.

#### Distribution

<b>Prepared by Gensler by</b>	Robert Fabijaniak	<b>Date Signed</b>	July 26, 2013
-------------------------------	-------------------	--------------------	---------------

#### Instructions / Description / References / Dates

In order to clarify the bid documents, the following modifications to the Master Table of Contents, Special Conditions, Appendices and Drawings are to be construed as part of the documents upon which bidders shall prepare their proposals and to supplant provisions appearing elsewhere in the documents which may be in conflict therewith. Material to be added is indicated by underline type. Material to be deleted is indicated by ~~striketrough type~~. The location of the changes on each page is also indicated by a vertical bar in the margin. The addendum number and date is indicated at the top of each page in the center of the header. Material to be revised on the drawings is indicated by a cloud with an addendum number and date indicated on the title block.

### **MASTER TABLE OF CONTENTS**

1. **Replace** TOC dated February 8, 2013 - with attached revised TOC dated July 25, 2013

### **00 00 10 – NOTICE TO CONTRACTORS CALLING FOR BIDS**

1. **Replace** section with attached revised section.

### **00 03 10 – AGREEMENT**

1. **Replace** section with attached revised section.

500 South Figueroa  
Los Angeles CA 90071

Tel: +1 213.327.3600  
Fax: +1 213.327.3601

---

<b>Project</b>	Ventura College - Applied Science Center	<b>Date</b>	July 26, 2013
<b>Project Location</b>	4667 Telegraph Road Ventura CA 93003	<b>This is page</b>	2 of 3

---

**00 08 00 – SPECIAL CONDITIONS**

1. **Replace** section with attached revised section.

**08 71 00 – DOOR HARDWARE**

1. **Replace** Section with attached revised section dated July 23, 2013.

**27 10 00 – COMMUNICATION CABLING**

1. **Replace** Section with attached revised section dated July 23, 2013.

**DRAWINGS**

1. **Revise** The Control Equipment Schedule and Exhaust Fan Schedule on Drawing M4.0 per attached sketch SKM-001.
2. **Replace** Drawing C100-01 DEMOLITION PLAN with attached revised drawing C100-01 DEMOLITION PLAN.
3. **Replace** Drawing C100-02 GRADING PLAN with attached revised drawing C100-02 GRADING PLAN.
4. **Replace** Drawing C100-03 GRADING DETAILS with attached revised drawing C100-03 GRADING DETAILS.
5. **Add** the Erosion Control Plan.

**BIDDERS' PRE-BID QUESTIONS/ SUBSTITUTIONS/ RFI's**

1. Question: I believe the spec on this project calls for hand finished pipe bollards. We manufacture a precast concrete bollard cap that makes this process faster, less expensive and completely uniform. If you get a second visit us at [www.topgardcap.com](http://www.topgardcap.com). There are some installation videos on the site that really demonstrate why this product makes sense. The product is stocked across the country so it is readily available for your job. Please contact me if you need more information or samples.

Answer: Yes, the hand finished pipe bollards can be substituted with a precast concrete bollard cap.

2. Question: Pre-Bid RFI 001 - The exterior elevations on plan sheets A09.01 & A09.02 indicate stainless steel reveal/joint strips. Spec. section 09 24 00-2.2-B.6 & 7 indicate galvanized steel for control joints. Please clarify the material/finish for the plaster control joints.

Answer: The exterior elevation call outs are correct - stainless steel reveal/joint strips shall be used.

3. Question: Pre-Bid RFI #002 - We were provided with a Geotechnical Study by Geotechniques dated July 2011. Section 6.0 – Recommendations refers to removal of existing underground utilities, building foundations, piles, etc. and to the overexcavation, recompaction and construction of the building pad. This

---

500 South Figueroa  
Los Angeles CA 90071

Tel: +1 213.327.3600  
Fax: +1 213.327.3601

# Addendum Number 001 continued

---

<b>Project</b>	Ventura College - Applied Science Center	<b>Date</b>	July 26, 2013
<b>Project Location</b>	4667 Telegraph Road Ventura CA 93003	<b>This is page</b>	3 of 3

---

work has already been done. Is there a soils report, or an addendum to the soils report, that addresses the recommendations for the earthwork required for the site in its current state? I believe at the job-walk Carole Wockner indicated that there was a report with recommendations for the clear & grub & earthwork now required.

Answer: refer to attached Project Memorandum - Response to Pre-Bid RFI #002

4. Question: We request clarification of which Division will be responsible for building and installing the upper lighting and utility structure to be installed in Room 120 Career Training, and shown in Detail 5.A12.65. Although it is designed to house power, comm. and lighting fixtures, it also appears to be a custom fabrication that would not be considered standard raceway materials provided for in Division 26000 Electrical.

Answer: All power systems are in conduits and as such do not need an additional raceway, they are not conductors without conduit. For additional info refer to Section 27100

26 02 70	Substation Transformers, Dry Type (Short) (by Lucci & Associates).....	3
26 02 80	Integrated Transient Voltage Surge Suppression Device(s) Panelboards (by Lucci & Associates).....	2
26 03 22	208-Volt Main Switchgear (by Lucci & Associates).....	5
26 03 40	Compact Compartmentalized Medium Voltage Metal-Enclosed Load Interrupter Switchgear (by Lucci & Associates) .....	9
26 24 20	Switchboards (by Lucci & Associates) .....	3
26 24 50	Grounding (by Lucci & Associates).....	5
26 24 60	Shielded Isolation Transformers (by Lucci & Associates).....	3
26 24 61	Dry Type Transformer (by Lucci & Associates) .....	3
26 24 80	Motor Starting Equipment and Wiring (by Lucci & Associates).....	5
26 25 10	Lighting Fixtures (by Lucci & Associates) .....	3
26 26 20	Emergency Generator (by Lucci & Associates).....	5
26 26 21	Automatic Transfer Switch (by Lucci & Associates) .....	2
26 47 15	Communications Backbone Cabling (by Lucci & Associates) .....	8
26 47 16	Communications Horizontal Cabling (by Lucci & Associates) .....	14
26 47 21	Fire Alarm System (by Lucci & Associates) .....	33
26 47 27	Security Access System (by Lucci & Associates) .....	3
26 47 45	<del>Networking &amp; Data Communications (by Lucci &amp; Associates)</del> <del>Section</del> .....	<del>17</del>
26 47 50	<del>Cabling and Distribution System (by Lucci &amp; Associates)</del> <del>Delete Section</del> .....	<del>48</del>
26 49 01	General Control Devices (by Lucci & Associates).....	3
26 49 20	Motor Control (by Lucci & Associates).....	4

**DIVISION 27 – COMMUNICATIONS**

<i>Date</i>	<i>Section No.</i>	<i>Title</i>	
	27 05 28	Cable Tray (by Vantage Technology).....	3
	27 10 00	Communications Cabling (by Vantage Technology).....	21
	27 41 00	Audiovisual Equipment-Speakers (by Vantage Technology).....	7
	27 51 00	Assistive Listening Systems (ALS) (by Vantage Technology) .....	5
	27 51 16	Audiovisual Equipment – Mounts (by Vantage Technology) .....	8

**DIVISION 28 – ELECTRONIC SAFETY AND SECURITY – Not Used**

DIVISION 29 – Reserved

**SITE AND INFRASTRUCTURE SUBGROUP**

DIVISION 30 – Reserved

**DIVISION 31 – EARTHWORK**

<i>Date</i>	<i>Section No.</i>	<i>Title</i>	
	31 10 00	Site Clearing (by Penfield & Smith).....	2
	31 20 00	Earth Moving (by Penfield & Smith) .....	6
	31 23 33	Trenching and Backfilling (by Penfield & Smith) .....	4
	31 62 13	Concrete Piles (by Saiful/Bouquet Inc.).....	10

**DIVISION 32 – EXTERIOR IMPROVEMENTS**

<i>Date</i>	<i>Section No.</i>	<i>Title</i>	
	32 11 23	Aggregate Base Courses (by Penfield & Smith) .....	2
	32 12 16	Asphalt Paving (by Penfield & Smith) .....	4

**SECTION 00010**  
**NOTICE TO CONTRACTORS CALLING FOR BIDS**

**DISTRICT:** VENTURA COUNTY COMMUNITY COLLEGE DISTRICT

**PROJECT IDENTIFICATION:** Ventura College Applied Science Center

**VCCCD PROJECT NO:** #39110 / Exhibit B Ref. #47

**BIDS DUE BY:** Thursday, August 22, 2013 at 3 p.m.

**SUBMIT BIDS TO:** Ventura County Community College District  
Capital Planning, Design and Construction  
255 W. Stanley Ave., Suite 150  
Ventura, CA 93001  
(805) 652-5500

**BID AND CONTRACT DOCUMENTS AVAILABLE:** CyberCopy  
3020 Sherwin Avenue, Suite A  
Ventura, CA 91361  
Ph: (805) 642-3292 Fax: (805) 642-3601  
e-mail [www.cybercopyusa.com](http://www.cybercopyusa.com)

**MANDATORY PRE-BID JOB WALK LOCATION:** Ventura College  
Heery Construction Trailer  
4667 Telegraph Road  
Ventura, CA 93003

**JOB WALK DATE/TIME:** Thursday, July 11, 2013, at 2 p.m.

**NOTICE IS HEREBY GIVEN** that Ventura County Community College District, acting by and through its Board of Trustees, hereinafter referred to as the "District," will receive up to, but not later than the above-stated date and time, sealed Bid Proposals for the Contract for the work generally described as the **Applied Science Center, Project #39110**.

**1.01 Submittal of Bid Proposals**

All Bid Proposals shall be submitted on forms furnished by the District. Bid Proposals must conform with, and be responsive to, the Bid and Contract Documents, copies of which may be obtained from the District as set forth above. Only Bid Proposals submitted to the District prior to the date and time set forth above for the public opening and reading of Bid Proposals shall be considered.

**1.02 Bid and Contract Documents**

Bidder may obtain, at Bidder's sole cost and expense, the Bid and Contract Documents at the location stated above.

**1.03 Bid Proposal**

Each Bid Proposal shall consist of:

- A.** Bid Proposal
- B.** Bid Security
- C.** List of Subcontractors

- D. Non-Collusion Affidavit
- E. Statement of Bidder's Qualifications

All information or responses of a Bidder in its Bid Proposal and other documents accompanying the Bid Proposal shall be complete, accurate and true; incomplete, inaccurate or untrue responses or information provided therein by a Bidder may be grounds for the District to reject such Bidder's Bid Proposal for non-responsiveness.

**1.04 Job-Walk**

The District will conduct a **MANDATORY PRE-BID JOB WALK** for the work to be held at the location, date and time stated above. Failure to attend will render the Bid Proposal of such bidder to be non-responsive.

**1.05 Prevailing Wage Rates; Employment of Apprentices and Labor Compliance Program**

The Project is subject to the provisions of Labor Code §§1720 *et seq.* and regulations set forth in Title 8 §§16000 *et seq.* of the California Code of Regulations which govern the payment of prevailing wages on public works projects. All bidders shall be governed by and required to comply with these statutes and regulations in connection with the Project. Pursuant to Labor Code §1771, the Contractor receiving award of the Contract and Subcontractors of any tier shall pay not less than the prevailing wage rates to all workers employed in the execution of the Contract. Bidders shall comply with applicable statutes and regulations, including but not limited to Labor Code §§ 1771, 1775, 1777.5, 1813 and 1815.

Pursuant to Labor Code §1773, the Director of the DIR has determined the generally prevailing rates of wages in the locality in which the Work is to be performed. Pursuant to Labor Code §1773.2, copies of these determinations, entitled "PREVAILING WAGE SCALE", are maintained at the District's Capital Planning, Design and Construction offices located at 333 Skyway Drive, Camarillo, CA 93010, and are available to any interested party upon request. Copies of rate schedules are also available on the Internet at [http://www.dir.ca.gov/DIR/S&R/statistics\\_research.html](http://www.dir.ca.gov/DIR/S&R/statistics_research.html). The Contractor awarded the Contract for the Work shall post a copy of all applicable prevailing wage rates for the Work at conspicuous locations at the Site of the Work.

Bidders are directed to Article 4.21 of Section 00700 (General Conditions) for detailed requirements concerning payment of prevailing wage rates, payroll records, hours of work, employment of apprentices, and the District's LCP requirements and enforcement procedures.

**1.06 Contractors License Classification**

In accordance with the provisions of California Public Contract Code §3300, the District requires that Bidders possess the following classification(s) of California Contractors License at the time that the Contract for the Work is awarded: Class B.

**1.07 Contract Time**

Substantial Completion of the Work shall be achieved within **Six Hundred Ten (610) Calendar Days** after the date for commencement of the Work as set forth in the Notice to Proceed issued by the District. Failure to achieve Substantial Completion within the Contract Time will result in the assessment of Liquidated Damages.

**1.08 Bid Security**

Each Bid Proposal shall be accompanied by Bid Security in an amount not less than **Ten Percent (10%)** of the maximum amount of the Bid Proposal, inclusive of any additive Alternate Bid Item(s). Failure of any Bid Proposal to be accompanied by Bid Security in the form and in the amount required shall render such Bid Proposal to be non-responsive and rejected by the District.

**1.09 No Withdrawal of Bid Proposals**

No Bidder shall withdraw its Bid Proposal for a period of **ninety (90) days** after the award of the Contract by the District's Board of Trustees. During this time, all Bidders shall guarantee prices quoted in their respective Bid Proposals.

**1.10 Substitute Security**

In accordance with the provisions of California Public Contract Code §22300, substitution of eligible and equivalent securities for any monies withheld by the District to ensure the Contractor's performance under the Contract will be permitted at the request and expense of the Contractor. The foregoing notwithstanding, the Bidder to whom the Contract is awarded shall have **thirty (30) days** following action by the District's Board of Trustees to award the Contract to such Bidder to submit its written request to the District to permit the substitution of securities for retention. The failure of the Bidder to make such written request to the District within said thirty (30) day period shall be deemed a waiver of the Bidder's rights under California Public Contract Code §22300.

**1.11 Waiver of Irregularities**

The District reserves the right to reject any or all Bid Proposals or to waive any irregularities or informalities in any Bid Proposal or in the bidding.

**1.12 Award of Contract**

The Contract for the Work, if awarded, will be by action of the District's Board of Education to the responsible Bidder submitting the lowest responsive Bid Proposal. If the Bid Proposal requires Bidders to propose prices for Alternate Bid Items, the District's selection of Alternate Bid Items, if any, for determination of the lowest priced Bid Proposal and for inclusion in the scope of the Contract to be awarded shall be in accordance with this Notice and the Instructions for Bidders.

**1.13 Inquiries and Clarifications**

This document is for informational purposes and shall not relieve the Bidder of the requirements to fully familiarize themselves with all the factors affecting the Project and his Bid. The Bidder is advised that all inquiries and clarifications about the Bid Documents, Drawings, Specifications, etc., shall be submitted to the District in writing at least **seven (7) days** before the bid opening date. The District will respond at its earliest possible opportunity. Verbal communication by either party with regard to this matter is invalid. Inquiries shall be sent to: Richard Magill, Heery International, Inc. c/o Ventura County Community College District, Capital Planning, Design and Construction, 103 Durley Ave., Camarillo, CA 93010, Phone: (805) 289-6080, Fax: (805) 654-6443, **E-mail: [rmagill@vcccd.net](mailto:rmagill@vcccd.net)**

**Publication Dates:**

June 21, June 26 and July 2, 2013

*[End of Section]*

**SECTION 00310**  
**AGREEMENT**

THIS AGREEMENT is made this \_\_\_\_\_ day of \_\_\_\_\_, 20\_\_\_\_, in the City of Ventura, County of Ventura, State of California, by and between VENTURA COUNTY COMMUNITY COLLEGE DISTRICT, a California Community College District, hereinafter called the "District" and \_\_\_\_\_, hereinafter called the "Contractor", with a principal place of business located at \_\_\_\_\_.

WITNESSETH, that the District and the Contractor in consideration of the mutual covenants contained herein agree as follows:

**1.01 The Work.** Within the Contract Time and for the Contract Price, subject to adjustments thereto pursuant to the Contract Documents, the Contractor shall perform and provide all necessary labor, materials, tools, equipment, utilities, services and transportation to complete in a workmanlike manner all of the Work required in connection with the work of improvement commonly referred to as the **Ventura College Applied Science Center**

Contractor shall complete all Work covered by the Contract Documents, including without limitation, the Drawings and Specifications prepared by the Architect, and other Contract Documents enumerated in Article 5 below, along with all modifications and addenda thereto issued in accordance with the Contract Documents.

**1.02 Contract Time.** The Work shall be commenced on the date stated in the District's Notice to Proceed. The Contractor shall achieve Substantial Completion of the Work within **Six Hundred Ten (610) calendar days** after the date stated in the District's Notice to Proceed (see Section 1.01 of the Contract Special Conditions and as otherwise provided in the Contract Documents).

**1.03 Contract Price.** The District shall pay the Contractor as full consideration for the Contractor's full, complete and faithful performance of the Contractor's obligations under the Contract Documents, subject to any additions or deduction as provided for in the Contract Documents, the Contract Price of \_\_\_\_\_ Dollars \$\_\_\_\_\_.

The Contract Price is based upon the Contractor's Base Bid Proposal.

The District's payment of the Contract Price shall be in accordance with the Contract Documents.

**1.04 Liquidated Damages.** In the event of the failure or refusal of the Contractor to achieve Completion of the Work of the Contract Documents within the Contract Time, as adjusted, the Contractor shall be subject to assessment of Liquidated Damages in accordance with the Contract Documents.

**1.05 The Contract Documents.** The Contract Documents consist of the following:

Notice to Contractors Calling for Bids	Labor and Material Payment Bond
Instructions for Bidders	Performance Bond
Bid Proposal	Certificate of Workers Compensation
Subcontractors List	Drug Free Workplace Certification
Non-Collusion Affidavit	General Conditions
Statement of Bidder's Qualifications	Special Conditions
Bid Bond	Specifications
Agreement	Drawings
	Guarantee



July 25, 2013  
Addendum #001

**1.06 Authority to Execute.** The individual(s) executing this Agreement on behalf of the Contractor is/are duly and fully authorized to execute this Agreement on behalf of Contractor and to bind the Contractor to each and every term, condition and covenant of the Contract Documents.

IN WITNESS WHEREOF, this Agreement has been duly executed by the District and the Contractor as of the date set forth above.

DISTRICT:

CONTRACTOR:

VENTURA COUNTY COMMUNITY COLLEGE  
DISTRICT,  
a California Community College District

\_\_\_\_\_  
(Contractor's License Number)

By: \_\_\_\_\_

By: \_\_\_\_\_

Name: \_\_\_\_\_

Name: \_\_\_\_\_

Title: \_\_\_\_\_

Title: \_\_\_\_\_

*[Corporate Seal]*

\_\_\_\_\_

*[End of Section]*

**SECTION 00800**  
**SPECIAL CONDITIONS**

**1.01 Contract Time**

**1.01.1 Substantial Completion of the Work**

The Work shall be commenced on the date stated in the Notice to Proceed issued by the District to the Contractor and shall be completed (Substantial Completion) within **Six Hundred Ten (610) Consecutive Calendar Days** from and after the date stated in the Notice to Proceed (Reference Article 7 of the General Conditions).

**1.02 Liquidated Damages**

**1.02.1 Delayed Completion of the Work**

Pursuant to Article 7 of the General Conditions, the Contractor shall be subject to the assessment and withholding of Liquidated Damages for failure to achieve Substantial Completion of the Work within the Contract Time as indicated in item 1.01.1, above. Liquidated Damages shall be at the rate of **Three Thousand Dollars (\$3,000)** per calendar day until Substantial Completion of the Work is achieved.

**1.02.2 Delayed Final Completion of the Work**

Pursuant to Article 7 of the General Conditions, the Contractor shall be subject to the assessment and withholding of Liquidated Damages for failure to achieve Final Completion of the Work within 90 days of Substantial Completion, in accordance with the Contract Documents. Liquidated Damages shall be at the rate of **One Thousand Dollars (\$1,000)** per calendar day until Final Completion of the Work is achieved.

**1.02.3 Delayed Submittals**

The per day assessment of Liquidated Damages for Contractor's delayed submission of Submittals pursuant to Article 4.8.2.1 of the General Conditions is **One Hundred Dollars (\$100)** per calendar day per Submittal until the required Submittal is submitted.

**1.02.4 Cumulative Accrual of Liquidated Damages**

If the Contractor fails to timely deliver the Submittals, fails to achieve Substantial Completion, or fails to achieve Final Completion of the Work, the Contractor shall be liable to the District for Liquidated Damages in the amounts set forth above for each such portion of the Work which is not timely delivered or completed within the time allocated for each portion of the Work, such amounts to accrue cumulatively until each such event is achieved in accordance with the Contract Documents.

**1.03 Insurance**

**1.03.1 Insurance Provided By Contractor**

Pursuant to Article 6 of the General Conditions, the Contractor shall provide and maintain the following insurance coverage amounts as set forth below:

- |  |   |
|--|---|
| <b>1. Workers Compensation Insurance</b>           |   |
|  | In accordance with limits established by law. |
| <b>2. Employers Liability Insurance:</b>           | \$1,000,000                                   |
| <b>3. Commercial General Liability Insurance</b>   |   |
|  | Per Occurrence \$2,000,000                    |
|  | Aggregate \$5,000,000                         |
| <b>4. Automobile Liability Insurance</b>           | \$1,000,000                                   |
| <b>5. Excess Products and Completed Operations</b> | \$2,000,000                                   |

**1.03.2 Insurance Provided by Subcontractors**

Pursuant to Article 6 of the General Conditions, all Subcontractors and Sub-Subcontractors shall provide and maintain the following insurance coverages, with minimum coverage amounts as set forth below:

- |  |  |
|--|--|
| <b>1. Workers Compensation Insurance</b>         |  |
|  | In accordance with limits established by law.            |
| <b>2. Employers Liability Insurance</b>          | \$1,000,000  |
| <b>3. Commercial General Liability Insurance</b> |  |
|  | Per Occurrence \$1,000,000                               |
|  | Aggregate \$2,000,000                                    |
| <b>4. Automobile Liability</b>                   |  |
|  | Bodily Injury/Property Damage Per Occurrence \$1,000,000 |

**1.04 Drawings and Specifications**

The number of sets of the Drawings and Specifications, which the District will provide to the Contractor, pursuant to Article 2.1.2 of the General Conditions, is Zero (0) sets of reproducible specifications with plans.

**1.05 Number of Contract Documents**

The number of executed copies of the Agreement is six (6); the number of Performance Bonds and Payment Bonds required is four (4).

**1.06 Security**

In addition to the security requirements set forth elsewhere in the Contract Documents, the Contractor must adhere to the following:

**1.06.1 Locked Door Policy**

No building, room or site gate shall be left unsecured for any period of time when not occupied by the Contractor and/or after the Contractor's daily work hours.

**1.07 Working Hours**

The working hours for this Contract shall be 7:00 a.m. to 7:00 p.m. Monday through Friday. Saturday/Sunday work requires written notification to and approval from the District.

Work hours are subject to standard construction hours per the Ordinance set by the City of Ventura, California. Contractor is expected to work weekends and holidays, as necessary, to complete the work within the specified time of completion without any additional cost to the District. At the District's request, Contractor shall modify the working hours for the Contract without adjustment of the Contract Time or Contract Price. (Reference General Conditions Article 7.2.1)

If any work performed during school hours is found to be disruptive to the educational process (as determined by the District), the contractor will be required to re-schedule subject work to occur during non-school hours without any additional cost to the District.

**1.08 Temporary Electric Power**

Provide temporary electric power as necessary for execution of work. The Contractor will arrange distribution service point for electric power with the utility company. Contractor shall provide meters, necessary wiring, switches, receptacles, etc., and make connections to distribution points. Contractor to pay all costs for temporary electric power.

**1.09 Temporary Lighting**

Provide lighting and outlets in temporary structures and wherever necessary for proper performance and inspection of work. If operations are performed during hours of darkness and whenever District's Project Manager deems natural lighting insufficient, provide adequate floodlights, clusters, and spot illumination, as required to facilitate reading of drawings and specifications. Make arrangements with subcontractors for electric services and lighting as necessary in performance of their work. Contractor to pay for all temporary lighting.

**1.10 Temporary Heat and Ventilation**

**1.10.1** Provide heat, fuel and services to protect the work against injury from dampness and cold until final acceptance of all work of the contract.

**1.10.2** When the new HVAC system is used for temporary heat and ventilation, comply with air quality requirements of ASHRAE 62, and the following:

**1.10.2.1** Temporary Filters for Air Systems: Provide temporary filters in air conditioning and ventilating systems to prevent dust and fumes from contaminating the new ductwork and equipment. Use commercial viscous-coated throw away filters, or equal, having efficiency of not less than 60 percent.

**1.10.2.2** At completion, inspect the entire system for dirt and debris. Clean equipment, ducts and plenums that are soiled, at no cost to the District.

**1.10.3** Before casework is delivered to the building, for not less than 5 days prior to installing wood finishes, and throughout placing of this finish and other finish operations such as painting and laying of resilient floor covering, sufficient heat to maintain building temperature at 65 degrees F.

**1.10.4** Operate HVAC system over a weekend as directed, for not less than 48 hours to purge VOC and other contaminants from the building.

## **1.11 Temporary Telephone and Fax Service**

**1.11.1** Provide, maintain and pay for duration of work, for temporary telephone and fax service including installation, maintenance and removal for construction needs. Provide one direct line telephone instrument at the first aid station.

## **1.12 Temporary Water Services**

**1.12.1** The District will provide and pay for water at existing mains as shown on the drawings. The Contractor shall provide meter and service lines to site. Temporary service lines shall be installed and removed by the Contractor, who shall pay all charges for making the connections, running temporary lines, installing meter, removing same at the completion of the work, and disconnecting the services.

**1.12.2** An approved double check valve shall be furnished and installed by the Contractor at the connection to the main.

**1.12.3** All relocations required to clear work of others shall be performed when requested by the Architect. The District reserves the right to make connections to the temporary lines by themselves or by other contractors. In the event the contractor uses the water in a wasteful manner, the Contractor will be billed District's cost for the wasted water.

**1.12.4** Per CAL OSHA requirements, drinking water shall be available in the Construction trailer.

**1.13 Temporary Gas**

Provide temporary gas service **as necessary** for execution of work. Contractor shall connect gas service to new meter in an approved manner. Gas used and all other costs including installation, maintenance and removal of temporary meter shall be paid by the Contractor.

**1.14 Temporary Sanitary Facilities**

Provide and maintain temporary toilet facilities for duration of operations. Properly proportion number of fixtures for the number of workers employed all in accordance with CAL OSHA requirements. Provide water tight and floored structures. Maintain in a clean and sanitary condition acceptable to District and Architect.

**1.15 Utility Costs for Subcontractors**

Distribution of temporary utility services to subcontractors shall be Contractor's responsibility.

**1.16 Temporary Fire Protection and Safety Requirements**

**1.16.1** The Contractor shall take necessary precautions to guard against and eliminate fire hazards and to prevent damage to construction work, building materials, equipment, temporary field offices, storage sheds, and public and private property. The Contractor shall be responsible for providing, maintaining, and enforcing the following conditions and requirements during the entire construction period.

**1.16.1.1** Fire Inspection: The Contractor's Superintendent shall inspect the entire project at least once each week to make certain that the conditions and requirements are being adhered to.

**1.16.1.2** Hose: The number of outlets, supply of hose, and proper hose size to protect the construction area shall be determined by the local Fire Marshal and provided by the Contractor.

**1.16.1.3** Fires: Employees shall not be allowed to start fires with gasoline or kerosene or other highly flammable materials. No open fires shall be allowed.

**1.16.1.4** Flammable Building Materials: Only a reasonable working supply of flammable building material shall be located inside of, or on the roof of, any storage facility.

**1.16.1.5** Combustible Waste Materials: Oil-soaked rags, papers, and other highly combustible materials must be stored in closed metal containers at all times, and shall be removed from the site at the close of each day's work and more often where necessary, and placed in metal containers with tight hinged lids.

**1.16.1.6** Gasoline and other flammable or polluting liquids/materials shall not be poured into sewers, manholes, or traps, but shall be disposed of, together with flammable or waste material subject to spontaneous combustion, in a safe manner meeting all applicable laws and ordinances. Make appropriate arrangements for storing these materials outside of the building.

**1.16.1.7** Provide and maintain fire extinguishers during construction, conveniently located for proper protection, one fire extinguisher for each 5,000 square feet of floor area or less, but not less than four extinguishers. Fire extinguishers shall be ten-pound ABC type. Extinguishers shall meet approval of Underwriter's Laboratory, and shall be inspected at regular intervals and recharged as necessary.

**1.17** All self-propelled construction equipment, except light service trucks, panels, pickups, station wagons, crawler type cranes, power shovels and draglines, whether moving alone or in combination, shall be equipped with a reverse signal alarm (hub-cap type).

**1.18 Temporary Offices**

**Contractor's Trailer**

**1.18.1** Prior to starting work, provide and maintain for duration of operations, temporary office facilities as required for Contractor's administration; likewise, all necessary sheds and facilities for proper storage of tools, materials, and equipment employed in performance of work.

**1.18.2** The office shall be a separate structure. The location of the office trailer will be determined at the time of mobilization to be acceptable to the District. The office structure shall be substantially and neatly constructed, weather-tight, well lighted, and neatly painted inside and out. The office shall be heated and cooled. It shall have doors that are separately keyed and two or more windows on opposite sides.

**1.18.3** The facilities for Contractor's use shall be not less than described herein. The facilities shall be of suitable size to accommodate the office and shall be furnished with whatever facilities the Contractor needs.

**1.18.4** Costs of the field offices and utilities, including cleaning service not less than once per week, shall be borne by the Contractor.

**Project Inspector's Office**

**1.18.5** Project Inspector's office space will be provided by the District.

## **1.19 Temporary Electronic Communications**

**1.19.1** Contractor shall provide at the site, in the office, the following equipment for each of the Contractor's personnel, such as Contractor's Project Manager, Superintendent, QC Manager, and all Contractor's project engineers.

- 1) One (1) computer with 19" LCD monitor containing:
  - a. 2.4 GHz Duo Core Pentium E6600 processor or faster
  - b. 2 GB RAM minimum
  - c. 300 GB hard drive minimum
  - d. One DVD ROM Drive
  - e. One 18x/8x/16x Dual Layer DVD ± RW Writer
  - f. 10/100 Ethernet Network Card
  - g. Two front mounted USB 2.0 ports and One Firewire port
  - h. Windows XP Professional Service Pack 2 (or later) OS

## **1.20 Temporary Scaffolding, Stairs, and Hoists**

Provide and maintain for duration of work, in accordance with CAL-OSHA and applicable laws and ordinances, all required temporary standing scaffolding, and temporary stairs, ladders, ramps, runways and hoists for use of all trades, unless otherwise specified in Contract Documents.

## **1.21 Temporary Guards, Barricades, and Lights**

**1.22.1** Provide construction canopies, barricades, fences, guards, railings, lights, and warning signs necessary and required by law, and take necessary precautions required to avoid injury or damage to any and all persons and property.

**1.22.2** Provide and maintain protective fences and barricades as shown on drawings and as Contractor may deem necessary to protect construction yard, storage areas and work in place, subject to approval as to type and appearance. Hog wire fencing is not acceptable. Remove all temporary fences and barricades upon project completion. Refer to site plan for layout.

## **1.22 Protection of Work and Facilities**

**1.22.1** Protect all adjacent property, roads, streets, curbs, shrubbery, lawns, erosion control materials and planting during construction operations. All damaged material shall be replaced and/or repaired at the expense of the Contractor. Maintain a chain link fence around the perimeter of the project's site for the duration of construction and if necessary patch damage due to fence installation.

**1.22.2** Upon completion deliver the entire work to the District in proper, whole and unblemished condition. Work outside of the immediate construction site shall be restored



to a whole and unblemished condition immediately upon completion of that portion of the work.

**1.22.2.1** Parts of work in place that are subject to injury, because of operations being carried on adjacent thereto, shall be covered, boarded up, or substantially enclosed with adequate protection.

**1.22.2.2** The Contractor shall be responsible for preventing the overloading of any part of the facilities beyond their safe calculated carrying capacity by the placing of materials and/or equipment, tools, machinery, or any other items thereon.

**1.22.2.3** The District may provide such watchman services deemed necessary to protect the District's interest, but any protection so provided by the District shall not relieve the Contractor of the responsibility for the safety and condition of the work and material until the completion and acceptance thereof. The Contractor shall employ such watchman services as he may deem necessary to properly protect and safeguard the work and material.

## **1.23 Special Controls**

### **1.23.1 Use of Powder-Driven Fasteners**

The use of powder set (cartridge type) anchors or lugs for attaching of any work is strictly prohibited on this project unless reviewed by the Architect and approved by the SEOR.

### **1.23.2 Use of Explosives**

Blasting will not be permitted unless approved in writing by the Architect.

### **1.23.3 Dust Control**

Throughout the entire Contract period, effectively dust-palliate the working area, roads, and storage areas constructed under this Contract and involved portions of the site, except during such periods that other contractors may be performing work of separate contracts in these areas. Such application shall consist of intermittent watering and sprinkling of such frequency as will satisfactorily allay the dust during all hours that work is being performed. At no time shall water be allowed to pond or puddle. Ponds and puddles shall be removed immediately and steps taken to remove or dry the mud resulting from the ponds or puddles.

## **1.24 Water Control**

Surface or subsurface water or other fluid shall not be permitted to accumulate in excavations or under the structures. Should such conditions develop or be encountered, the water or other fluid shall be controlled and suitably disposed of by means of temporary pumps, piping, drainage lines and ditches, dams or other methods approved by the Architect.

**1.25 Project Identification**

Provide and maintain one sign only on the property at location as directed by Architect. Signboard shall contain information and be of size as detailed on the drawings. Small direction signs may be installed if specifically approved by Architect. Signs by subcontractors and material suppliers will not be permitted.

**1.26 Contractor Vehicles on Campus**

Contractor's vehicles shall be restricted to access routes established by the District. Parking of Contractor's employees' vehicles will be limited to areas as established by the District, not necessarily adjacent to the site.

**1.27 Removal of Temporary Construction**

Remove temporary office facilities, toilets, storage sheds, fences, and other construction of temporary nature from site as soon as progress of work permits. Recondition and restore portions of site occupied by same to a condition acceptable to Architect.

**1.28 Use of Facilities**

The Contractor and subcontractor shall not, during hours of construction or at times when they are on site to perform work under the contract, use any of the campus facilities, including but not limited to, the restrooms, phones and roadways and the like without prior permission of the campus M & O Director.

**1.29 Damages**

The Contractor shall be responsible to report and repair, at no additional cost to the District, any damage to College property caused by Contractor, Contractor's employees, Subcontractors, material suppliers, or any other persons or entities, which are onsite as a result of the Contract and work there under. Contractor shall notify the District Project Manager in writing within four (4) hours of the occurrence, and provide a description of the damage and the exact location. The Contractor shall immediately contact the M&O Director, the Project Manager and IOR, and immediately repair the damage using materials of equal or superior grade to that which was damaged. No backfilling or covering up of damage or repairs shall be performed by the Contractor until such time as the District representative has inspected the work and provided the Contractor with written approval to cover the work.

**1.30 Waste Management**

Contractor shall not use the campus dumpsters, or dispose of waste or any other items, on Campus.

**1.31 State and College Regulations**

The Contractor and his Subcontractors shall comply with all District, City, County and State regulations regarding noise, dust, smoke, fire and safety rules, and shall keep the site and surrounding areas clean and free of debris.

**1.32 Drawings and Plans**

The terms “drawings” and “plans” are used interchangeable in the Contract Documents and have the same meaning.

**1.33 Approval for Commencement of Work**

The Contractor shall obtain approval from the Facilities Planning & Construction Office/Maintenance & Operations Director before commencing work in any existing occupied area, or before working on existing piping, wiring, or equipment. The Contractor shall indicate the particular area where work will be in progress and the length of time any existing system will be out of service. This work is to be scheduled in such a manner so as not to disrupt present operations, where possible. If new construction requires interruption of present operations, the Contractor shall obtain approval from the parties named above, after providing them with specific information regarding areas, dates, hours of the day, and number of hours any interruption is expected to take place. All interruption of services shall be approved by the District, in writing, prior to such interruptions and at the sole discretion of the District. The Contractor shall perform such work on weekends, after regular working hours, or in incremental blocks of time as directed by the District, at no additional cost to the contract price. Work performed as herein described shall not be a basis for an extension to the contract time for completion of all work.

**1.34 Verify Existing Conditions**

The Contractor shall verify, identify and locate all utilities (above and below grade, visible and concealed), and all conditions and dimensions of the Work as described in the Contract Documents, prior to starting construction. All Subcontractors shall verify at the Site all conditions and measurements related to their work.

**1.35 Scaling Dimensions from Drawings**

In no case shall working dimensions be scaled from plans, sections, or details from the Working Drawings. If no dimension is shown, the Contractor shall request in writing that the Architect provide clarification and dimensions.

**1.36 Similar Conditions**

The intent is to provide a fully functional finished product, complete in every respect. Where a specific detail is not shown, the construction shall be similar to that indicated or noted for similar conditions and as necessary for a complete installation. References of notes and details to specific conditions and locations shall not limit their applicability. Materials for similar use shall be of the same type and manufacturer, unless otherwise indicated or specified as different. Any deviation must be approved in writing, by the Architect and District, prior to incorporation into the work.

**1.37 Handicap Access Regulations**

The Contractor and all Subcontractors shall comply with Title 24, Disabled Access Regulations and ADA, Americans with Disabilities Act Regulations, whether or not

specifically indicated on the Contract Documents. Where existing paths of travel are interrupted due to construction, barrier-free paths of travel shall be maintained by the Contractor, without adjustment to Contract Price or Contract Time.

**1.38 Items marked “N.I.C.” (Not in Contract)**

Items marked N.I.C. in the Drawings are not part of the Work. In most instances, they are included for coordination under this Contract of the Work with concurrent or future work outside this contract. However, the Contractor shall review all items marked N.I.C. and provide the District and Architect notice and deadline dates of when the items are needed onsite for coordination and incorporation into the project. Failure by the Contractor to give notice to the District and Architect, and to provide such notice in sufficient time so as to allow District to select, order and receive the items shall not be the basis for delay claims, time extensions, or increased cost to the contract price.

**1.39 Coordination for all Trades**

The Contractor shall be responsible for the proper location and size of openings for all trades, and shall coordinate all construction as indicated by the Contract Documents, including Shop Drawings reviewed by the Architect.

**1.40 Items Not Identified in Construction Documents**

Any conditions or installations not identified in the Contract Documents and affecting the Work to be performed shall be brought to the attention of the Architect in order that cost and responsibility for any added work may be determined before work is undertaken. The Contractor’s notice to the Architect of such installations or conditions shall be in writing. Pending receipt of written direction from the Architect, the Contractor shall not disturb or perform construction operations in any area affected by such installations or conditions.

**1.41 Vehicular Access and Parking**

Construction, which might affect existing College vehicular access and parking, shall be scheduled during non-school hours. The Contractor shall immediately vacate any area if Contractor’s operations or activities curtail vehicular access to the campus or to parking. Fire Department vehicular access to and around the construction area shall be maintained at all times by the Contractor clear of obstruction. Contractor shall provide keys to all gates to local Fire Department and District representatives for gate access.

**1.42 Right of Access**

The District, or its representative(s), and the Architect shall be able at all times to enter the construction site and observe the work. They shall have the right to reject defective materials and workmanship and to require appropriate corrections at the Contractor’s expense. The Contractor shall not be relieved of any responsibility under this contract to provide materials and equipment in accordance with the Contract Documents for failure by the Architect and/or District representatives to discover, or otherwise bring to the attention of the Contractor, any deficiencies with the work.

**1.43 Restoration of Existing Conditions**

The Contractor shall restore all landscaping, paving, and grading to the original condition at all areas adjoining the construction sites. Prior to performing any work on the project, the Contractor shall, at his sole expense, locate and mark the locations of all components of the irrigation systems which will, or may be, affected by or interfere with work under the contract. The Contractor shall meet with the Facilities Planning & Construction Office/Director of Maintenance & Operations Office to develop a plan and schedule to expose and rework the irrigation system as necessary to maintain continuous uninterrupted functioning of the irrigation system. In the event that irrigation lines, sprinklers, control wiring or the like are damaged, the Contractor shall notify the District Project Manager/Director of Maintenance & Operations Office representative within one (1) hour, and within four (4) hours of the occurrence provide a written description of the damage and its exact location. The Contractor shall immediately repair the damage using materials of equal or superior grade to that which was damaged. No backfilling or covering up of damage or repair shall be performed by the Contractor until such time as the Facilities Planning & Construction Office/Director of Maintenance & Operations Office representative has inspected the work and provided the Contractor with written approval to cover the work.

**1.44 Municipal Laws and Regulations**

The Contractor shall have full knowledge of, and at no additional cost to the contract comply with, all laws and regulations including, but not limited to, limitations on noise, hours of operation, hauling routes or limits on weight of equipment traveling on adjacent streets, and any other limitations which might affect the Contractor's work and operations.

**1.45 Weekend Hours**

The contract time is expressed in calendar days. The Contractor may perform work, with prior notification as per Article 1.07 of the Special Conditions, on weekends or holidays, at his discretion. Should it be necessary for inspectors, District personnel, consultants, or Project Manager to visit the work site on weekends or holidays, additional cost, if any, shall be reimbursed to the District by the Contractor. The District, at its sole discretion, may direct certain portions of the work to be performed after hours, or on weekends or holidays, in order to minimize interruption to the academic operations of the College. The Contractor shall reflect in his Progress Schedule all work, which may impact academic operations, and at Contractor's sole expense, and as directed by the District, perform all work at times convenient to the District.

**1.46 Testing and Inspection Costs**

**1.46.1** All costs for testing and inspection shall be paid by the District. However, the Contractor shall be responsible for all costs incurred for re-testing that may be required due to failed tests. Upon receipt from the Contractor of a Progress Schedule in accordance with the Contract Documents, the District shall provide a copy of the Progress Schedule

to the Testing Laboratory and obtain from them a cost to perform all necessary inspections for the project based on the timeframes set forth in the Progress Schedule. The Contractor shall reimburse the District for quantities, which exceed the scheduled amounts of time.

**1.46.2** If the Contractor uses a fabricator or supplier subject to DSA inspection or documentation from beyond a 100 mile radius of the Project Site, costs above and beyond those for the same inspections and documentation were it to occur within a 100 mile radius of the Project Site, including, but not limited to, out of state tests and inspections, per diem, travel, or the like, will be paid by the District and the District shall be reimbursed by the Contractor upon submittal by the District to the Contractor of the costs incurred.

**1.47 Needless Requests for Information**

Any needless Request for Information (RFI) will be billed to the Contractor by the A/E team at the additional service rate contained in their respective contracts. A needless RFI is any request for which an answer is in the plans or specifications, or Contract related correspondence, prior to the date of the RFI. Needless punch list visits will be billed in the same way.

**1.48 E-Mail Address**

All parties shall have an Email address and be responsible for all correspondence distributed via Email.

**1.49 Service Charges**

Electrical, water, telephone, and other utility charges will be billed to the contract at the same rate paid by the Ventura County Community College District (VCCCD).

**1.50 Material Substitutions**

Any and all material specification substitutions must be submitted to the Architect for approval no later than ten (10) days prior to the bid due date. Any substitutions submittal after that date will not be accepted.

**1.51 Electronic Schedule Files**

Pursuant to the requirements of the General Conditions under Article 7, the Contractor shall provide copies of project schedules submitted to the District on paper, including but not limited to, weekly, semi-monthly & monthly schedule updates, on compact discs, in

the proper file format to function in the scheduling program provided by the Contractor to the District as required under Article 7 of the General Conditions.

**1.52 Changes to the Work for Contractor Convenience**

Any changes to the Work resulting from a request by the Contractor to deviate from the approved Contract Documents or as a result of the Contractor not following the Contract

Documents that requires additional architectural or engineering services, including but not limited to document submittal to the Division of State Architects (DSA), will be billed to the Contractor by the A/E team at the additional service rate contained in their respective contracts.

**1.53 Mark-Ups on Changes to the Work**

In the event of Changes to the Work, the mark-up for all general conditions, costs, overhead (including home and field office overhead), profit and bond, shall not exceed **Twenty Percent (20%)** of the direct actual costs of the performance of an additive Change, as determined in accordance with the provisions of Article 9.4 of the General Conditions. However, in the event that Contractor self-performs the entirety of the Change, the mark-up for all general conditions, costs, overhead (including home and field office overhead), profit and bond, shall not exceed **Fifteen Percent (15%)** of the direct actual costs of the performance of an additive Change, as determined in accordance with the provisions of Article 9.4 of the General Conditions. In addition, the mark-up shall include the actual, direct cost of the bond for such Change.

The foregoing limitation or mark-up shall apply regardless of the number of subcontractors, of any tier, performing any portion of such additive Change to the Work. In the event that the Work of such additive Change is performed in part by a subcontractor, Contractor agrees to allocate at least Ten Percent (10%) to such subcontractor. In the event the Change is deductive, the District shall receive a credit equal to the value of the direct actual costs of the Work of the deductive Change plus Five (5%) of such direct actual costs for all general conditions, overhead (including home and field office overhead), profit and bond. General Contractor may charge Overhead and Profit based on the direct cost to the Subcontractor(s). General Contractor's Overhead and Profit shall not be charged or calculated on top of, or as percentage of, the Subcontractor(s) or Vendor's Overhead and Profit.

**1.54 Allowances**

The following allowances are in addition to the scope of the Work as defined in the Contract Documents and the Contractor shall add all Allowances to complete the work and shall include the total Allowances amount in the Bid Proposal Lump Sum Amount (Refer to Bid Proposal, Section 00210).

List of Allowances

Item	Description	Amount (\$)
1	No Allowance included in the Project	[Enter Amount(s)]
2		

The District may utilize the above allowances up to the total amount during the course of construction by issuing a Work Order(s) to the Contractor. A deductive Change Order will be issued at the completion of the Work to return the entire balance of the unused allowances to the District, without application of any mark-up.

**1.55 Inclement Weather Days**

Pursuant to Article 7.4.1 of the General Conditions, the number of Working Rain Days (including inclement weather) for this Contract is Thirty (30) days.

**1.56 District's Project Manager**

The District's Project Manager is:

Heery International, Inc.  
c/o Ventura County Community College District  
Capital Planning, Design and Construction  
103 Durley Ave.  
Camarillo, CA 93010  
Phone: (805) 384-8152 Fax: (805) 384-8155

**1.57 Communication via Fax**

Contractor's fax machine shall be in service at all times 24/7 for the duration of the contract.

**1.58 Storm Water Prevention Pollution Plan, SWPPP**

Contractor is responsible to implement and maintain the SWPPP to comply with all local and State regulatory requirements.

*[End of Section]*



## SECTION 08 71 00 – DOOR HARDWARE

### PART 1 - GENERAL

#### 1.1 SUMMARY

- A. Section includes commercial door hardware for the following:
  - 1. Swinging doors.
  - 2. Other doors to the extent indicated.
- B. Door hardware includes, but is not necessarily limited to, the following:
  - 1. Mechanical door hardware.
  - 2. Automatic operators.
  - 3. Cylinders specified for doors in other Sections.
- C. Related Sections:
  - 1. Section 06 10 53 "Miscellaneous Rough Carpentry."
  - 2. Section 08 11 13 "Hollow Metal Doors and Frames."
  - 3. Section 08 14 16 "Flush Wood Doors."
  - 4. Section 08 41 13 "Aluminum-Framed Entrances and Storefronts."
  - 5. Section 08 71 13 "Automatic Door Operators."
  - 6. Section 08 80 00 "Glazing."
  - 7. Section 09 91 13 "Exterior Painting."
  - 8. Section 09 91 23 "Interior Painting."

#### 1.2 REFERENCES

- A. Comply with the version year adopted by the Authority Having Jurisdiction.
  - 1. ANSI A117.1 - Accessible and Usable Buildings and Facilities.
  - 2. ANSI/SDI A250.13 - Testing and Rating of Severe Windstorm Resistant Components for Swing Door Assemblies.
  - 3. ASTM E1886 - Test Method for Performance of Exterior Windows, Curtin Walls, Doors and Shutters Impacted by Missiles and Exposed to Cyclic Pressure Differentials.
  - 4. ASTM E330 - Standard Test Method for Structural Performance of Exterior Windows, Curtain Walls, and Doors by Uniform Static Air Pressure difference.
  - 5. ASTM E1996 - Standard specification for performance of exterior windows, curtain walls, doors and storm shutters impacted by Windborne Debris in Hurricanes.
  - 6. FEMA 361 2008 - Design and Construction Guidance for Community Safe Rooms.
  - 7. ICC 500 - ICC/NSSA Standard for the Design and Construction of Storm Shelters.
  - 8. ICC/IBC - International Building Code.
  - 9. NFPA 70 - National Electrical Code.
  - 10. NFPA 80 - Fire Doors and Windows.

11. NFPA 101 - Life Safety Code.
12. NFPA 105 - Installation of Smoke Door Assemblies.
13. TAS-201-94 - Impact Test Procedures.
14. TAS-202-94 - Criteria for Testing Impact and Non-Impact Resistant Building Envelope Components using Uniform Static Air Pressure.
15. TAS-203-94 - Criteria for Testing Products Subject to Cyclic Wind Pressure Loading.
16. 2010 California Building Code

B. Standards: All hardware specified herein shall comply with the following industry standards:

1. ANSI/BHMA Certified Product Standards - A156 Series.
2. UL10C – Positive Pressure Fire Tests of Door Assemblies.

### 1.3 ACTION SUBMITTALS

A. Product Data: For each type of product indicated. Include construction and installation details, material descriptions, dimensions of individual components and profiles, and finishes.

B. CALgreen Submittals:

1. Product Data for Section 5.504.4.1: For sealants, adhesives and caulks, provide documentation including printed statement of VOC content showing compliance with SCAQMD Rule 1168 VOC limits and CCR Title 17 for aerosols.
2. Product Certificates for Section A5.405.1: For products and materials required to comply with requirements for regional materials, certificates indicating location of material manufacturer and point of extraction, harvest, or recovery for each raw material. For the purposes of this requirement, "regional" is interpreted to mean within 500 miles of the project location or within the State of California.

C. Shop Drawings: Details of electrified door hardware, indicating the following:

1. Wiring Diagrams: For power, signal, and control wiring and including the following:
  - a. Details of interface of electrified door hardware and building safety and security systems.
  - b. Schematic diagram of systems that interface with electrified door hardware.
  - c. Point-to-point wiring.
  - d. Risers.
  - e. Elevations doors controlled by electrified door hardware.
2. Operation Narrative: Describe the operation of doors controlled by electrified door hardware.

D. Samples for Verification: For exposed door hardware of each type required, in each finish specified, prepared on Samples of size indicated below. Tag Samples with full description for coordination with the door hardware schedule. Submit Samples before, or concurrent with, submission of door hardware schedule.

1. Sample Size: Full-size units or minimum 2-by-4-inch (51-by-102-mm) Samples for sheet and 4-inch (102-mm) long Samples for other products.
  - a. Full-size Samples will be returned to Contractor. Units that are acceptable and remain undamaged through submittal, review, and field comparison process may, after final check of operation, be incorporated into the Work, within limitations of keying requirements.

E. Other Action Submittals:

1. Door Hardware Schedule: Prepared by or under the supervision of Installer, detailing fabrication and assembly of door hardware, as well as installation procedures and diagrams. Coordinate final door hardware schedule with doors, frames, and related work to ensure proper size, thickness, hand, function, and finish of door hardware.
  - a. Submittal Sequence: Submit door hardware schedule concurrent with submissions of Product Data, Samples, and Shop Drawings. Coordinate submission of door hardware schedule with scheduling requirements of other work to facilitate the fabrication of other work that is critical in Project construction schedule.
  - b. Format: Use same scheduling sequence and format and use same door numbers as in the Contract Documents.
  - c. Content: Include the following information:
    - 1) Identification number, location, hand, fire rating, size, and material of each door and frame.
    - 2) Locations of each door hardware set, cross-referenced to Drawings on floor plans and to door and frame schedule.
    - 3) Complete designations, including name and manufacturer, type, style, function, size, quantity, function, and finish of each door hardware product.
    - 4) Description of electrified door hardware sequences of operation and interfaces with other building control systems.
    - 5) Fastenings and other pertinent information.
    - 6) Explanation of abbreviations, symbols, and codes contained in schedule.
    - 7) Mounting locations for door hardware.
    - 8) List of related door devices specified in other Sections for each door and frame.
2. Keying Schedule: Prepared by or under the supervision of Installer, detailing Owner's final keying instructions for locks. Include schematic keying diagram and index each key set to unique door designations that are coordinated with the Contract Documents.

1.4 INFORMATIONAL SUBMITTALS

A. Product Certificates: For electrified door hardware, from the manufacturer.

1. Certify that door hardware approved for use on types and sizes of labeled fire-rated doors complies with listed fire-rated door assemblies.

- B. Product Test Reports: For compliance with accessibility requirements, based on evaluation of comprehensive tests performed by manufacturer and witnessed by a qualified testing agency, for door hardware on doors located in accessible routes.
- C. Warranty: Special warranty specified in this Section.

#### 1.5 CLOSEOUT SUBMITTALS

- A. Maintenance Data: For each type of door hardware to include in maintenance manuals. Include final hardware and keying schedule.

#### 1.6 QUALITY ASSURANCE

- A. Installer Qualifications: Supplier of products and an employer of workers trained and approved by product manufacturers and an Architectural Hardware Consultant who is available during the course of the Work to consult with Contractor, Architect, and Owner about door hardware and keying.
  - 1. Warehousing Facilities: In Project's vicinity.
  - 2. Scheduling Responsibility: Preparation of door hardware and keying schedules.
  - 3. Engineering Responsibility: Preparation of data for electrified door hardware, including Shop Drawings, based on testing and engineering analysis of manufacturer's standard units in assemblies similar to those indicated for this Project.
- B. Architectural Hardware Consultant Qualifications: A person who is experienced in providing consulting services for door hardware installations that are comparable in material, design, and extent to that indicated for this Project and who is currently certified by DHI as follows:
  - 1. For door hardware, an Architectural Hardware Consultant (AHC).
- C. Source Limitations: Obtain each type of door hardware from a single manufacturer.
  - 1. Provide electrified door hardware from same manufacturer as mechanical door hardware, unless otherwise indicated. Manufacturers that perform electrical modifications and that are listed by a testing and inspecting agency acceptable to authorities having jurisdiction are acceptable.
- D. Fire-Rated Door Assemblies: Where fire-rated door assemblies are indicated, provide door hardware rated for use in assemblies complying with NFPA 80 that are listed and labeled by a qualified testing agency, for fire-protection ratings indicated, based on testing at positive pressure according to NFPA 252 or UL 10C, unless otherwise indicated.
- E. Smoke- and Draft-Control Door Assemblies: Where smoke- and draft-control door assemblies are required, provide door hardware that meet requirements of assemblies tested according to UL 1784 and installed in compliance with NFPA 105.
  - 1. Air Leakage Rate: Maximum air leakage of 0.3 cfm/sq. ft. (3 cu. m per minute/sq. m) at the tested pressure differential of 0.3-inch wg (75 Pa) of water.

- F. Electrified Door Hardware: Listed and labeled as defined in NFPA 70, Article 100, by a testing agency acceptable to authorities having jurisdiction.
- G. Means of Egress Doors: Latches do not require more than 15 lbf (67 N) to release the latch. Locks do not require use of a key, tool, or special knowledge for operation. The unlatching force shall not exceed 15 lbs, applied in the direction of travel.
- H. Accessibility Requirements: For door hardware on doors in an accessible route, comply with the U.S. Architectural & Transportation Barriers Compliance Board's ADA-ABA Accessibility Guidelines and DSA's "California Access Compliance Reference Manual."
  - 1. Provide operating devices that do not require tight grasping, pinching, or twisting of the wrist and that operate with a force of not more than 5 lbf (22.2 N).
  - 2. Panic hardware shall not be provided with "Night Latch" (NL) function that requires the exit unlatching with tight grasping, pinching or twisting of the wrist to operate (CBC Section 1008.1.9.1), or with more than one operation (1008.1.9.5).
  - 3. Panic hardware shall comply with CBC. Section 1008.1 .9. Panic bar shall be mounted at 36" to 44" above finished floor. (Consider that if the device is mounted lower than 36" AFF, the clear opening may be restricted to less than the 32" required clear opening).
  - 4. Mounting height of latching hardware shall be 30" to 44" A.F.F. per CBC Section 1133B.2.5.2.
  - 5. Comply with the following maximum opening-force requirements:
    - a. Interior, Non-Fire-Rated Hinged Doors: 5 lbf (22.2 N) applied perpendicular to door.
    - b. Sliding or Folding Doors: 5 lbf (22.2 N) applied parallel to door at latch.
    - c. Fire Doors: Minimum opening force allowable by authorities having jurisdiction.
  - 6. Bevel raised thresholds with a slope of not more than 1:2. Provide thresholds not more than 1/2 inch (13 mm) high.
  - 7. Adjust door closer sweep periods so that, from an open position of 70 degrees, the door will take at least 3 seconds to move to a point 3 inches (75 mm) from the latch, measured to the leading edge of the door.
  - 8. Door closers, when provided, shall have sweep period adjusted so that from an open position of 70 degrees, the door will take at least 3 seconds to move to a point 3" from the strike. CBC Section 1133B2.5.1.
  - 9. Pressure to operate doors shall not exceed: 5 lbs for exterior doors, and 5 lbs for interior doors. When fire doors are required, the maximum effort to operate the doors shall not exceed 5 lbs, except that, when approved by the appropriate administrative authority, the maximum effort required to operate th~ doors may be increased not to exceed 15 lbs. CBC Sections 1008.1.3 and 1133B.2.51 ADAAG 4.13.11 .
  - 10. Thresholds shall comply with CBC Sections 1008.1.7 and 1133B.2.4.1.
  - 11. Floor stops shall not be located in the path of travel and 4" maximum from walls. DSA Policy 99-08.

- I. Keying Conference: Conduct conference at Project site to comply with requirements in Division 01 Section "Project Management and Coordination." In addition to Owner Contractor, and Architect, conference participants shall also include Installer's Architectural Hardware Consultant and Owner's security consultant. Incorporate keying conference decisions into final keying schedule after reviewing door hardware keying system including, but not limited to, the following:
  - 1. Function of building, flow of traffic, purpose of each area, degree of security required, and plans for future expansion.
  - 2. Preliminary key system schematic diagram.
  - 3. Requirements for key control system.
  - 4. Requirements for access control.
  - 5. Address for delivery of keys.
  
- J. Preinstallation Conference: Conduct conference at Project site Insert location.
  - 1. Review and finalize construction schedule and verify availability of materials, Installer's personnel, equipment, and facilities needed to make progress and avoid delays.
  - 2. Inspect and discuss preparatory work performed by other trades.
  - 3. Inspect and discuss electrical roughing-in for electrified door hardware.
  - 4. Review sequence of operation for each type of electrified door hardware.
  - 5. Review required testing, inspecting, and certifying procedures.

#### 1.7 DELIVERY, STORAGE, AND HANDLING

- A. Inventory door hardware on receipt and provide secure lock-up and shelving for door hardware delivered to Project site. Do not store electronic access control hardware, software or accessories at Project site without prior authorization.
- B. Tag each item or package separately with identification related to the final Door Hardware Schedule, and include basic installation instructions with each item or package.
- C. Deliver, as applicable, permanent keys, cylinders, cores, access control credentials, software and related accessories directly to Owner via registered mail or overnight package service. Instructions for delivery to the Owner shall be established at the "Keying Conference."

#### 1.8 COORDINATION

- A. Templates: Obtain and distribute to the parties involved templates for doors, frames, and other work specified to be factory prepared for installing standard and electrified hardware. Check Shop Drawings of other work to confirm that adequate provisions are made for locating and installing hardware to comply with indicated requirements.
- B. Door Hardware and Electrical Connections: Coordinate the layout and installation of scheduled electrified door hardware and related access control equipment with required connections to source power junction boxes, low voltage power supplies, detection and monitoring hardware, and fire and detection alarm systems.

- C. Door and Frame Preparation: Related Division 08 Sections (Steel, Aluminum and Wood) doors and corresponding frames are to be prepared, reinforced and pre-wired (if applicable) to receive the installation of the specified electrified, monitoring, signaling and access control system hardware without additional in-field modifications.

#### 1.9 WARRANTY

- A. General Warranty: Reference Division 01, General Requirements. Special warranties specified in this Article shall not deprive Owner of other rights Owner may have under other provisions of the Contract Documents and shall be in addition to, and run concurrent with, other warranties made by Contractor under requirements of the Contract Documents.
- B. Warranty Period: Written warranty, executed by manufacturer(s), agreeing to repair or replace components of standard and electrified door hardware that fails in materials or workmanship within specified warranty period after final acceptance by the Owner. Failures include, but are not limited to, the following:
  - 1. Structural failures including excessive deflection, cracking, or breakage.
  - 2. Faulty operation of the hardware.
  - 3. Deterioration of metals, metal finishes, and other materials beyond normal weathering.
  - 4. Electrical component defects and failures within the systems operation.
- C. Standard Warranty Period: One year from date of Substantial Completion, unless otherwise indicated.
- D. Special Warranty Periods:
  - 1. Ten years for mortise locks and latches.
  - 2. Five years for exit hardware.
  - 3. Ten years for manual door closers.
  - 4. Two years for electromechanical door hardware.

#### 1.10 MAINTENANCE SERVICE

- A. Maintenance Tools and Instructions: Furnish a complete set of specialized tools and maintenance instructions as needed for Owner's continued adjustment, maintenance, and removal and replacement of door hardware.
- B. Continuing Service: Beginning at Substantial Completion, and running concurrent with the specified warranty period, provide continuous six months full maintenance including repair and replacement of worn or defective components, lubrication, cleaning, and adjusting as required for proper door opening operation. Provide parts and supplies as used in the manufacture and installation of original products.

## PART 2 - PRODUCTS

### 2.1 SCHEDULED DOOR HARDWARE

- A. General: Provide door hardware for each door to comply with requirements in Door Hardware Sets and each referenced section that products are to be supplied under.
1. Designations: Requirements for quantity, item, size, finish or color, grade, function, and other distinctive qualities of each type of door hardware are indicated in the Door Hardware Sets at the end of Part 3. Products are identified by using door hardware designations, as follows:
    - a. Named Manufacturer's Products: Product designation and manufacturer are listed for each door hardware type required for the purpose of establishing requirements. Manufacturers' names are abbreviated in the Door Hardware Schedule.
    2. Products furnished, but not installed, under this Section include the following. Coordinating, purchasing, delivering, and scheduling remain requirements of this Section.
      - a. Permanent cylinders, cores, and keys to be installed by Owner.

### 2.2 HANGING DEVICES

- A. Hinges: ANSI/BHMA A156.1 certified butt hinges with number of hinge knuckles as specified in the Door Hardware Sets.
1. Quantity: Provide the following hinge quantity, unless otherwise indicated:
    - a. Two Hinges: For doors with heights up to 60 inches.
    - b. Three Hinges: For doors with heights 61 to 90 inches.
    - c. Four Hinges: For doors with heights 91 to 120 inches.
    - d. For doors with heights more than 120 inches, provide 4 hinges, plus 1 hinge for every 30 inches of door height greater than 120 inches.
  2. Hinge Size: Provide the following, unless otherwise indicated, with hinge widths sized for door thickness and clearances required:
    - a. Widths up to 36 Inches: 4-1/2 inches standard or heavy weight as specified.
    - b. Sizes from 37 Inches to 48 Inches: 5 inches standard or heavy weight as specified.
  3. Hinge Weight and Base Material: Unless otherwise indicated, provide the following:
    - a. Exterior Doors: Heavy weight, non-ferrous, ball bearing hinges unless Hardware Sets indicate standard weight.
    - b. Interior Doors: Standard weight, steel, ball bearing hinges unless Hardware Sets indicate heavy weight.



4. Hinge Options: Comply with the following where indicated in the Hardware Sets or on Drawings:
  - a. Non-removable Pins: Provide set screw in hinge barrel that, when tightened into a groove in hinge pin, prevents removal of pin while door is closed; for the following applications:
    - 1) Out-swinging exterior doors.
    - 2) Out-swinging access controlled doors.

5. Acceptable Manufacturers:

- a. Hager Companies (HA).
- b. McKinney Products (MK).
- c. Stanley Hardware (ST).

- B. Continuous Geared Hinges: ANSI/BHMA A156.26 certified continuous geared hinge with minimum 0.120-inch thick extruded 6060 T6 aluminum alloy hinge leaves and a minimum overall width of 4 inches. Hinges are non-handed, reversible and fabricated to template screw locations. Provide concealed flush mount (with or without inset), full surface, or half surface, in standard and heavy duty models, as specified in the Hardware Sets. Concealed continuous hinges to be U.L. listed for use on up to and including 90 minute rated door installations and U.L. listed for windstorm components where applicable. Factory cut hinges for door size and provide with removable service power transfer panel where indicated at electrified openings.

1. Acceptable Manufacturers:

- a. McKinney Products (MK).
- b. Pemko Manufacturing (PE).

## 2.3 DOOR OPERATING TRIM

- A. Flush Bolts and Surface Bolts: ANSI/BHMA A156.3 and A156.16, Grade 1, certified automatic, self-latching, and manual flush bolts and surface bolts. Manual flush bolts to be furnished with top rod of sufficient length to allow bolt location approximately six feet from the floor. Furnish dust proof strikes for bottom bolts. Surface bolts to be minimum 8" in length and U.L. listed for labeled fire doors and U.L. listed for windstorm components where applicable. Provide related accessories (mounting brackets, strikes, coordinators, etc.) as required for appropriate installation and operation.

1. Acceptable Manufacturers:

- a. McKinney Architectural Hardware (MK).
- b. Rockwood Manufacturing (RO).

- B. Door Push Plates and Pulls: ANS/BHMA A156.6 certified door pushes and pulls of type and design specified below or in the Hardware Sets. Coordinate and provide proper width and height as required where conflicting hardware dictates.

1. Push/Pull Plates: Minimum .050 inch thick, 4-inches wide by 16-inches high, with square corners and beveled edges, secured with exposed screws unless otherwise indicated.
2. Straight Pull Design: Minimum 1-inch round diameter stainless steel bar or tube stock pulls with 2 1/2-inch projection from face of door unless otherwise indicated.
3. Offset Pull Design: Minimum 1-inch round diameter stainless steel bar or tube stock pulls with 2 1/2-inch projection and offset of 90 degrees unless otherwise indicated.
4. Push Bars: Minimum 1-inch round diameter horizontal push bars with minimum clearance of 2 1/2-inch projection from face of door unless otherwise indicated.
5. Fasteners: Provide manufacturer's designated fastener type as indicated in Hardware Sets.
  - a. Acceptable Manufacturers:
    - 1) McKinney Architectural Hardware (MK).
    - 2) Rockwood Manufacturing (RO).

## 2.4 CYLINDERS AND KEYING

- A. General: Cylinder manufacturer to have minimum ten years experience designing secured master key systems and have on record a published security keying system policy.
- B. Source Limitations: Obtain each type of keyed cylinder and keys from the same source manufacturer as locksets and exit devices, unless otherwise indicated.
- C. Cylinders: Original manufacturer cylinders complying with the following:
  1. Mortise Type: Threaded cylinders with rings and straight- or clover-type cam.
  2. Rim Type: Cylinders with back plate, flat-type vertical or horizontal tailpiece, and raised trim ring.
  3. Mortise and rim cylinder collars to be solid and recessed to allow the cylinder face to be flush and be free spinning with matching finishes.
- D. Permanent Cores: Manufacturer's standard; finish face to match lockset; complying with the following:
  1. Removable Cores: Core insert, removable by use of a special key, and for use with only the core manufacturer's cylinder and door hardware. Provide removable core (small or large format) as specified in Hardware Sets.
- E. Keying System: Each type of lock and cylinders to be factory keyed. Conduct specified "Keying Conference" to define and document keying system instructions and requirements. Furnish factory cut, nickel-silver large bow permanently inscribed with a visual key control number as directed by Owner. Incorporate decisions made in keying conference, and as follows:
  1. Existing System: Master key or grand master key locks to Owner's existing Corbin/Russwin IC system.
- F. Key Quantity: Provide the following minimum number of keys:
  1. Top Master Key: One

2. Change Keys per Cylinder: Two
3. Master Keys (per Master Key Group): Two
4. Grand Master Keys (per Grand Master Key Group): Two
5. Construction Control Keys (where required): Two
- 5-6. Construction Keys: Ten
- 6-7. Permanent Control Keys (where required): Two~~Four~~

- G. Construction Keying: Provide construction ~~master keyed cylinders or~~ temporary keyed construction cores where specified. Provide construction ~~master~~ keys in quantity as required by project Contractor. Replace construction cores with permanent cores. Furnish permanent cores for installation as directed under specified "Keying Conference".
- H. Key Registration List: Provide keying transcript list to Owner's representative in the proper format for importing into key control software.

## 2.5 MECHANICAL LOCKS AND LATCHING DEVICES

- A. Mortise Locksets, Grade 1 (Heavy Duty): ANSI/BHMA A156.13, Series 1000, Operational Grade 1 certified mortise locksets furnished in the functions as specified in the Hardware Sets. Locksets to be manufactured with a corrosion resistant, stamped 12 gauge minimum formed steel case and be field-reversible for handing without disassembly of the lock body. Lockset trim (including knobs, levers, escutcheons, roses) to be the product of a single manufacturer. Furnish with standard 2 3/4 inch backset, 3/4-inch throw anti-friction stainless steel latchbolt, and a full 1-inch throw stainless steel bolt for deadbolt functions.

1. Acceptable Manufacturers:

- a. ~~Corbin Russwin Hardware (RU)~~ Schlage Lock (SC) – L9000 ML2000 Series.

- B. Lock Trim Design: As specified in Hardware Sets.06A

## 2.6 LOCK AND LATCH STRIKES

- A. Strikes: Provide manufacturer's standard strike with strike box for each latch or lock bolt, with curved lip extended to protect frame, finished to match door hardware set, unless otherwise indicated, and as follows:

1. Flat-Lip Strikes: For locks with three-piece antifriction latchbolts, as recommended by manufacturer.
2. Extra-Long-Lip Strikes: For locks used on frames with applied wood casing trim.
3. Aluminum-Frame Strike Box: Provide manufacturer's special strike box fabricated for aluminum framing.

- B. Standards: Comply with the following:

1. Strikes for Mortise Locks and Latches: BHMA A156.13.
2. Strikes for Bored Locks and Latches: BHMA A156.2.
3. Strikes for Auxiliary Deadlocks: BHMA A156.5.

4. Dustproof Strikes: BHMA A156.16.

## 2.7 CONVENTIONAL EXIT DEVICES

- A. Conventional Push Rail Exit Devices (Heavy Duty): ANSI/BHMA A156.3, Grade 1 certified panic and fire exit hardware devices furnished in the functions specified in the Hardware Sets.
  1. Acceptable Manufacturers:
    - a. *Von Duprin (VO) – XP98 Series.*

## 2.8 DOOR CLOSERS

- A. All door closers specified herein shall meet or exceed the following criteria:
  1. General: Door closers to be from one manufacturer, matching in design and style, with the same type door preparations and templates regardless of application or spring size. Closers to be non-handed with full sized covers including installation and adjusting information on inside of cover.
  2. Standards: Closers to comply with UL-10C and UBC 7-2 for Positive Pressure Fire Test and be U.L. listed for use of fire rated doors.
  3. Size of Units: Comply with manufacturer's written recommendations for sizing of door closers depending on size of door, exposure to weather, and anticipated frequency of use. Where closers are indicated for doors required to be accessible to the physically handicapped, provide units complying with ANSI ICC/A117.1 provisions for door opening force and delayed action closing.
  4. Closer Arms: Provide heavy duty, forged steel closer arms unless otherwise indicated in Hardware Sets.
    - a. Where closers are indicated to have mechanical dead-stop, provide heavy duty arms and brackets with an integral positive stop.
    - b. Where closers are indicated to have mechanical hold open, provide heavy duty units with an additional built-in mechanical holder assembly designed to hold open against normal wind and traffic conditions. Holder to be manually selectable to on-off position.
    - c. Where closers are indicated to have a cushion-type stop, provide heavy duty arms and brackets with spring stop mechanism to cushion door when opened to maximum degree.
  5. Closer Accessories: Provide door closer accessories including custom templates, special mounting brackets, spacers and drop plates, and through-bolt or security type fasteners as specified in the door Hardware Sets.
- B. Door Closers, Surface Mounted (Heavy Duty): ANSI/BHMA A156.4, Grade 1 surface mounted, heavy duty door closers with complete spring power adjustment, sizes 1 thru 6; and fully operational adjustable according to door size, frequency of use, and opening force. Closers to be rack and pinion type, one piece cast iron ~~or aluminum alloy~~ body construction, with

adjustable backcheck and separate non-critical valves for closing sweep and latch speed control. Provide non-handed units and high impact, non-corrosive plastic covers standard.

1. Acceptable Manufacturers:
  - a. LCN Closers (LC) - 4040XP Series.

## 2.9 ARCHITECTURAL TRIM

### A. Door Protective Trim

1. General: Door protective trim units to be of type and design as specified below or in the Hardware Sets.
2. Size: Fabricate protection plates (kick, armor, or mop) not more than 2" less than door width (LDW) on stop side and not more than 1" less than door width on pull side. Coordinate and provide proper width and height as required where conflicting hardware dictates. Height to be as specified in the Hardware Sets.
3. Metal Protection Plates: ANSI/BHMA A156.6 certified metal protection plates (kick, armor, or mop), beveled on four edges (B4E), fabricated from the following.
  - a. Stainless Steel: .050-inch thick, with countersunk screw holes (CSK).
  - b. Brass or Bronze: .050-inch thick, with countersunk screw holes (CSK).
  - c. Laminate Plastic or Acrylic: 1/8-inch thick, with countersunk screw holes (CSK).
4. Fasteners: Provide manufacturer's designated fastener type as specified in the Hardware Sets.
5. Metal Door Edging: Door protection edging fabricated from a minimum .050-inch thick metal sheet, formed into an angle or "U" cap shapes, surface or mortised mounted onto edge of door. Provide appropriate leg overlap to account for protection plates as required. Height to be as specified in the Hardware Sets.
6. Acceptable Manufacturers:
  - a. McKinney Architectural Hardware (MK).
  - b. Rockwood Manufacturing (RO).
  - b-c. Ives Manufacturing (IV)

## 2.10 DOOR STOPS AND HOLDERS

- A. General: Door stops and holders to be of type and design as specified below or in the Hardware Sets.
- B. Door Stops and Bumpers: ANSI/BHMA A156.16, Grade 1 certified door stops and wall bumpers. Provide wall bumpers, either convex or concave types with anchorage as indicated, unless floor or other types of door stops are specified in Hardware Sets. Do not mount floor

stops where they will impede traffic. Where floor or wall bumpers are not appropriate, provide overhead type stops and holders.

1. Acceptable Manufacturers:

- a. McKinney Architectural Hardware (MK).
- b. Rockwood Manufacturing (RO).
- ~~b.c.~~ Ives Manufacturing (IV)

- C. Overhead Door Stops and Holders: ANSI/BHMA A156.6, Grade 1 certified overhead stops and holders to be surface or concealed types as indicated in Hardware Sets. Track, slide, arm and jamb bracket to be constructed of extruded bronze and shock absorber spring of heavy tempered steel. Provide non-handed design with mounting brackets as required for proper operation and function.

1. Acceptable Manufacturers:

- a. Rixson Door Controls (RF).
- b. Rockwood Manufacturing (RO).
- c. Ives Manufacturing (IV)
- e. ~~Sargent Manufacturing (SA).~~

## 2.11 ARCHITECTURAL SEALS

- A. General: Thresholds, weatherstripping, and gasket seals to be of type and design as specified below or in the Hardware Sets. Provide continuous weatherstrip gasketing on exterior doors and provide smoke, light, or sound gasketing on interior doors where indicated. At exterior applications provide non-corrosive fasteners and elsewhere where indicated.
- B. Smoke Labeled Gasketing: Assemblies complying with NFPA 105 that are listed and labeled by a testing and inspecting agency acceptable to authorities having jurisdiction, for smoke control ratings indicated, based on testing according to UL 1784.
1. Provide smoke labeled perimeter gasketing at all smoke labeled openings.
- C. Fire Labeled Gasketing: Assemblies complying with NFPA 80 that are listed and labeled by a testing and inspecting agency acceptable to authorities having jurisdiction, for fire ratings indicated, based on testing according to UL-10C.
1. Provide intumescent seals as indicated to meet UL10C Standard for Positive Pressure Fire Tests of Door Assemblies, and UBC 7-2, Fire Tests of Door Assemblies.
- D. Sound-Rated Gasketing: Assemblies that are listed and labeled by a testing and inspecting agency, for sound ratings indicated, based on testing according to ASTM E 1408.
- E. Replaceable Seal Strips: Provide only those units where resilient or flexible seal strips are easily replaceable and readily available from stocks maintained by manufacturer.
- F. Acceptable Manufacturers:

1. McKinney Weatherstripping Products (MW).
2. Pemko Manufacturing (PE).
- ~~2.3.~~ National Guard Products (NG)

## 2.12 FABRICATION

- A. Fasteners: Provide door hardware manufactured to comply with published templates generally prepared for machine, wood, and sheet metal screws. Provide screws according to manufacturers recognized installation standards for application intended.

## 2.13 FINISHES

- A. Standard: Designations used in the Hardware Sets and elsewhere indicate hardware finishes complying with ANSI/BHMA A156.18, including coordination with traditional U.S. finishes indicated by certain manufacturers for their products.
- B. Provide quality of finish, including thickness of plating or coating (if any), composition, hardness, and other qualities complying with manufacturer's standards, but in no case less than specified by referenced standards for the applicable units of hardware.
- C. Protect mechanical finishes on exposed surfaces from damage by applying a strippable, temporary protective covering before shipping.

## PART 3 - EXECUTION

### 3.1 EXAMINATION

- A. Examine scheduled openings, with Installer present, for compliance with requirements for installation tolerances, labeled fire door assembly construction, wall and floor construction, and other conditions affecting performance.
- B. Notify architect of any discrepancies or conflicts between the door schedule, door types, drawings and scheduled hardware. Proceed only after such discrepancies or conflicts have been resolved in writing.

### 3.2 PREPARATION

- A. Hollow Metal Doors and Frames: Comply with ANSI/DHI A115 series.
- B. Wood Doors: Comply with ANSI/DHI A115-W series.

### 3.3 INSTALLATION

- A. Install each item of mechanical and electromechanical hardware and access control equipment to comply with manufacturer's written instructions and according to specifications.

1. Installers are to be trained and certified by the manufacturer on the proper installation and adjustment of fire, life safety, and security products including: hanging devices; locking devices; closing devices; and seals.
- B. Mounting Heights: Mount door hardware units at heights indicated in following applicable publications, unless specifically indicated or required to comply with governing regulations:
  1. Standard Steel Doors and Frames: DHI's "Recommended Locations for Architectural Hardware for Standard Steel Doors and Frames."
  2. Wood Doors: DHI WDHS.3, "Recommended Locations for Architectural Hardware for Wood Flush Doors."
  3. Where indicated to comply with accessibility requirements, comply with ANSI A117.1 "Accessibility Guidelines for Buildings and Facilities."
  4. Provide blocking in drywall partitions where wall stops or other wall mounted hardware is located.
- C. Retrofitting: Install door hardware to comply with manufacturer's published templates and written instructions. Where cutting and fitting are required to install door hardware onto or into surfaces that are later to be painted or finished in another way, coordinate removal, storage, and reinstallation of surface protective trim units with finishing work specified in Division 9 Sections. Do not install surface-mounted items until finishes have been completed on substrates involved.
- D. Thresholds: Set thresholds for exterior and acoustical doors in full bed of sealant complying with requirements specified in Section 07 92 00 "Joint Sealants."
- E. Storage: Provide a secure lock up for hardware delivered to the project but not yet installed. Control the handling and installation of hardware items so that the completion of the work will not be delayed by hardware losses before and after installation.
- F. Door Closer installations: College requests all surface applied door closers to be installed in parallel arm configuration to reduce vandalism issues.

### 3.4 FIELD QUALITY CONTROL

- A. Field Inspection: Supplier will perform a final inspection of installed door hardware and state in report whether work complies with or deviates from requirements, including whether door hardware is properly installed, operating and adjusted.

### 3.5 ADJUSTING

- A. Initial Adjustment: Adjust and check each operating item of door hardware and each door to ensure proper operation or function of every unit. Replace units that cannot be adjusted to operate as intended. Adjust door control devices to compensate for final operation of heating and ventilating equipment and to comply with referenced accessibility requirements.



3.6 CLEANING AND PROTECTION

- A. Protect all hardware stored on construction site in a covered and dry place. Protect exposed hardware installed on doors during the construction phase. Install any and all hardware at the latest possible time frame.
- B. Clean adjacent surfaces soiled by door hardware installation.
- C. Clean operating items as necessary to restore proper finish. and provide final protection and maintain conditions that ensure door hardware is without damage or deterioration at time of owner occupancy.

3.7 DEMONSTRATION

- A. Instruct Owner's maintenance personnel to adjust, operate, and maintain mechanical and electromechanical door hardware.

3.8 DOOR HARDWARE SCHEDULE

- A. The hardware sets represent the design intent and direction of the owner and architect. They are a guideline only and should not be considered a detailed hardware schedule. Discrepancies, conflicting hardware and missing items should be brought to the attention of the architect with corrections made prior to the bidding process. Omitted items not included in a hardware set should be scheduled with the appropriate additional hardware required for proper application and functionality.

- B. Manufacturer's Abbreviations:

- 1. MK – McKinney
- 2. PE – Pemko
- 3. RO – Rockwood
- 4. ~~SC - Schlage~~RU – Corbin Russwin
- 5. BL – Blumcraft
- 6. RF – Rixson
- 7. LC - LCN Closers
- 8. DM - Dor-O-Matic
- 9. VO – Von Duprin

**Set: 01**

Doors: 100A

2 Pivot Set	147	626 RF
6 Intermediate Pivot	M19	626 RF
1 Exit Device	H-100B	626 BL

1 Exit Device	H-100B w/ cyl	626	BL
1 <u>IC Mortise</u> Cylinder	1080-114- CT6B	626	RU
1 <u>Permanent Core</u> <del>Interchangeable Core</del>	8000-	626	RU
2 Automatic Operator	Provided by Section 08 71 13		BE
4 Actuator	Provided by Section 08 71 13		BE
1 Bollard Post	Provided by Section 08 71 13		BE
2 Concealed Overhead Stop	1-X36 LS	630	RF
2 Sweep	18062CNB		PE
1 Threshold	272A Full Notch MSES25		PE

Notes: Seals are furnished by the door supplier.  
Verify cylinder type for Blumcraft exit device.

**Set: 02**

Doors: 120B

2 Floor Closer	PH27 LFP	626	RF
6 Intermediate Pivot	M19	626	RF
1 Exit Device	H-100B	626	BL
1 Exit Device	H-100B w/ cyl	626	BL
1 <u>IC Mortise Cylinder</u> <del>Cylinder</del>	1080-114- CT6B	626	RU
1 <u>Permanent Core</u> <del>Interchangeable Core</del>	8000-	626	RU
2 Concealed Overhead Stop	1-X36 LS	630	RF
2 Sweep	18062CNB		PE
1 Threshold Assembly	Type 13-276A Full Notch MSES25		PE

Notes: Seals are furnished by the door supplier.  
Verify cylinder type for Blumcraft exit device.

**Set: 03**

Doors: 100B, 101

2 Floor Closer	PH27 LFP	626	RF
6 Intermediate Pivot	M19	626	RF
1 Exit Device	H-100B	626	BL
1 Exit Device	H-100B w/ cyl	626	BL
1 <u>IC Mortise Cylinder</u> <del>Cylinder</del>	1080-114- CT6B	626	RU
1 <u>Permanent Core</u> <del>Interchangeable Core</del>	8000-	626	RU
2 Concealed Overhead Stop	1-X36 LS	630	RF

1 Threshold Assembly	Type 13-276A Full Notch MSES25	PE
2 Sweep	18062CNB	PE

Notes: Seals are furnished by the door supplier.  
Verify cylinder type for Blumcraft exit device.

**Set: 04**

Doors: 106

8 Hinge	TA2314 x NRP 4-1/2" x 4-1/2"	630	MK
1 Removable Mullion	<i>KR4954 x MT64</i>	689	<i>RUVO</i>
1 Exit device	<i>CD-XP98EO x VR910DT</i>	630	<i>RUVO</i>
1 Exit device	<i>CD-XP98NL-OP x VR910NL</i>	630	<i>RUVO</i>
1 <u>IC Rim Cylinder Interchangeable Core Cylinder</u>	<i>3080-178 CT6B</i>	626	RU
3 <u>IC Mortise Cylinder Interchangeable Core Cylinder</u>	<i>1080-114 CT6B</i>	626	RU
4 <u>Permanent Core</u>	<u>8000-</u>	626	RU
2 Surface Closer	4040+XP EDA	AL	LC
2 Door Stop	406	630	RO
1 Rain Guard	346C		PE
1 Gasketing	S773BL (Head & Jamb)		PE
2 Sweep	18062CNB		PE
1 Threshold	272A Full Notch MSES25		PE
1 Mullion Seal	5110		PE

**Set: 05**

Doors: 130B, 140B

2 Continuous Hinge	CFM120HD1		PE
1 Exit Device	<i>CD-9849EO CVC</i>	630	<i>VO</i>
1 Exit Device	<i>CD-9849NL-OP CVC</i>	630	<i>VO</i>
1 <u>IC Rim Cylinder Interchangeable Core Cylinder</u>	<i>3080-178 CT6B</i>	626	RU
2 <u>IC Mortise Cylinder Interchangeable Core Cylinder</u>	<i>1080-114 CT6B</i>	626	RU
3 <u>Permanent Core</u>	<u>8000-</u>	626	RU
2 Pull	RM2640-16	630	RO
2 Astragal	18041CNB		PE

2 Surface Closer	4040+XP EDA	AL LC
2 Protection Plate	K1050 10" 4BE	630 RO
2 Door Stop	481H	626 RO
1 Rain Guard	346C	PE
1 Gasketing	S773BL (Head & Jamb)	PE
2 Sweep	18062CNB	PE
1 Threshold	272A Full Notch MSES25	PE

**Set: 06**

Doors: 150C

1	Continuous Hinge	CFMXXHD1	PE
1	Exit Device	<del>XP98-EO</del>	<del>630 VO</del>
1	Surface Closer	4040+XP EDA	AL LC
1	Protection Plate	K1050 10" 4BE	630 RO
1	Door Stop	406	630 RO
1	Rain Guard	346C	PE
1	Gasketing	S773BL (Head & Jamb)	PE
1	Threshold	2005AT Full Notch MSES25SS	PE
2	Gasketing	ACP112BL	PE
1	Door Bottom	420APKL	PE

**Set: 07**

Doors: 120A

2 Floor Closer	PH27 LFP	626 RF
6 Intermediate Pivot	M19	626 RF
1 Exit Device	H-100B	626 BL
1 Exit Device	H-100B w/ cyl	626 BL
1 <del>IC Mortise Cylinder</del> <u>Cylinder</u>	1080-114- CT6B	626 RU
1 <del>Permanent Core</del> <u>Interchangeable Core</u>	8000-	626 RU
2 Concealed Overhead Stop	1-X36	630 RF
1 Threshold Assembly	Type 13-276A Full Notch MSES25	PE

Notes: Seals are furnished by the door supplier.  
Verify cylinder type for Blumcraft exit device.

**Set: 08**

Doors: 130A

2 Continuous Hinge	CFMHD1	PE
2 Exit Device	<i>CD9849-L CVC</i>	<i>630 VO</i>
2 <u>IC Rim Cylinder</u> <del>Interchangeable Core Cylinder</del>	<i>3080-178 CT6B</i>	626 RU
2 <u>IC Mortise Cylinder</u> <del>Interchangeable Core Cylinder</del>	<i>1080-114 CT6B</i>	<i>626 RU</i>
4 <u>Permanent Core</u>	<u>8000-</u>	<u>626 RU</u>
2 Astragal	18041CNB	PE
2 Surface Closer	4040+ <u>XP</u> EDA	AL LC
2 Protection Plate	K1050 10" 4BE	630 RO
2 Concealed Overhead Stop	1-X36	630 RF
2 Silencer	608	RO

**Set: 09**

Doors: 140A

2 Continuous Hinge	CFMHD1	PE
1 Exit Device	<i>CD9849EO CVC LBL</i>	<i>630 VO</i>
1 Exit Device	<i>CD9849NL-OP CVC LBL</i>	<i>630 VO</i>
1 <u>IC Rim Cylinder</u> <del>Interchangeable Core Cylinder</del>	<i>3080-178 CT6B</i>	626 RU
2 <u>IC Mortise Cylinder</u> <del>Interchangeable Core Cylinder</del>	<i>1080-114 CT6B</i>	<i>626 RU</i>
3 <u>Permanent Core</u>	<u>8000-</u>	<u>626 RU</u>
2 Pull	RM3301-72 TB MP	630 RO
2 Astragal	18041CNB	PE
2 Surface Closer	4040+ <u>XP</u> EDA	AL LC
2 Protection Plate	K1050 10" 4BE	630 RO
2 Concealed Overhead Stop	1-X36	630 RF
2 Silencer	608	RO

**Set: 10**

Doors: 150A, 150B

2 Continuous Hinge	CFMHD1	PE
1 Exit Device	<i>CD9849EO CVC LBL</i>	<i>630 VO</i>
1 Exit Device	<i>CD9849NL-OP CVC LBL</i>	<i>630 VO</i>
1 <u>IC Rim</u> <del>Interchangeable Core Cylinder</del>	<i>3080-178 CT6B</i>	626 RU
2 <u>IC Mortise</u> <del>Interchangeable Core Cylinder</del>	<i>1080-114 CT6B</i>	<i>626 RU</i>
3 <u>Permanent Core</u>	<u>8000-</u>	<u>626 RU</u>
2 Pull	RM3301-72 TB MP	630 RO
2 Astragal	18041CNB	PE

2 Surface Closer	4040+ XP EDA	AL LC
2 Protection Plate	K1050 10" 4BE	630 RO
2 Concealed Overhead Stop	1-X36 LS	630 RF
1 Gasketing	S773BL (Head & Jamb)	PE
2 Gasketing	ACP112BL	PE
2 Door Bottom	434ARL	PE
1 Threshold	As Detailed	PE

**Set: 11**

Doors: 102, 105, 142, 143, 152

4 Hinge	TA2714 x NRP 4-1/2" x 4-1/2"	626 MK
1 Storeroom Lock	<del>L9080L 06A ML2057 NSA CT6B</del>	630 <del>SCRU</del>
1 <del>IC Mortise Interchangeable Core Cylinder</del>	<del>1080-114 CT6B 8000-</del>	626 RU
1 <u>Permanent Core</u>	<u>8000-</u>	<u>626 RU</u>
1 Door Stop	406	630 RO
3 Silencer	608	RO

**Set: 12**

Doors: 103, 104

4 Hinge	TA2714 4-1/2" x 4-1/2"	626 MK
1 Push Plate	70C	630 RO
1 Pull Plate	106x70C	630 RO
1 Automatic Operator	Provided by Section 08 71 13	BE
4 Actuator	Provided by Section 08 71 13	BE
1 Protection Plate	K1050 10" 4BE	630 RO
1 Door Stop	406	630 RO
3 Silencer	608	RO

**Set: 13**

Doors: 110, 111, 141

4 Hinge	TA2714 4-1/2" x 4-1/2"	626 MK
1 Office Lock	<del>L9050L 06A ML2051 NSA CT6B</del>	630 <del>RUSC</del>
1 <del>IC Mortise Cylinder Interchangeable Core</del>	<del>1080-114 CT6B 8000-</del>	626 RU
1 <u>Permanent Core</u>	<u>8000-</u>	<u>626 RU</u>
1 Door Stop	406	630 RO

3 Silencer 608 RO

**Set: 14**

Doors: 112

4 Hinge	TA2714 x NRP 4-1/2" x 4-1/2"	626	MK
1 Classroom Lock	<del>L9071L 06A ML2055 NSA CT6B</del>	630	<del>RU</del> SC
<del>2+</del> <u>IC Mortise Cylinder</u> <del>Interchangeable Core</del>	<del>1080-114 CT6B 8000-</del>	626	RU
<u>2 Permanent Core</u>	<u>8000-</u>	<u>626</u>	<u>RU</u>
1 Surface Closer	4041 EDA	AL	LC
1 Protection Plate	K1050 10" 4BE	630	RO
1 Door Stop	406	630	RO
3 Silencer	608		RO

**Set: 15**

Doors: 113

4 Hinge (heavy weight)	T4A3786 4-1/2" x 4-1/2"	626	MK
1 Classroom Lock	<del>L9071L 06A ML2055 NSA CT6B</del>	630	<del>RU</del> SC
<del>2+</del> <u>IC Mortise Interchangeable</u> <del>Core Cylinder</del>	<del>1080-114 CT6B 8000-</del>	626	RU
<u>2 Permanent Core</u>	<u>8000-</u>	<u>626</u>	<u>RU</u>
1 Surface Closer	4040+ <u>XP</u> EDA	AL	LC
1 Protection Plate	K1050 10" 4BE	630	RO
1 Door Stop	406	630	RO
3 Silencer	608		RO

**Set: 16**

Doors: 114

4 Hinge (heavy weight)	T4A3786 NRP 4-1/2" x 4-1/2"	626	MK
1 Classroom Lock	<del>L9071L 06A ML2055 NSA CT6B</del>	630	<del>RU</del> SC
<del>2+</del> <u>IC Mortise Interchangeable</u> <del>Core Cylinder</del>	<del>1080-114 CT6B 8000-</del>	626	RU
<u>2 Permanent Core</u>	<u>8000-</u>	<u>626</u>	<u>RU</u>
1 Surface Closer	4040+ <u>XP</u> EDA	AL	LC

1	Protection Plate	K1050 10" 4BE	630	RO
1	Door Stop	406	630	RO
3	Silencer	608		RO

**Set: 17**

Doors: 115

4	Hinge	TA2714 x NRP 4-1/2" x 4-1/2"	626	MK
1	Classroom Lock	<u>L9071L 06A ML2055 NSA</u> <u>CT6B</u>	630	<u>RU</u> <u>SC</u>
<del>2</del>	<del>IC Mortise Interchangeable Core Cylinder</del>	<del><u>1080-114 CT6B 8000-</u></del>	626	RU
<u>2</u>	<u>Permanent Core</u>	<u>8000-</u>	<u>626</u>	<u>RU</u>
1	Surface Closer	4040+ <u>XP</u> EDA		AL LC
1	Protection Plate	K1050 10" 4BE	630	RO
1	Concealed Overhead Stop	1-X36	630	RF
3	Silencer	608		RO

**Set: 18**

Doors: 144

4	Hinge	TA2714 4-1/2" x 4-1/2"	626	MK
1	Storeroom Lock	<u>L9080L 06A ML2057 NSA</u> <u>CT6B</u>	630	<u>SC</u> <u>RU</u>
1	<del>IC Mortise Interchangeable Core Cylinder</del>	<del><u>1080-114 CT6B 8000-</u></del>	626	RU
<u>1</u>	<u>Permanent Core</u>	<u>8000-</u>	<u>626</u>	<u>RU</u>
1	Door Stop	406	630	RO
3	Silencer	608		RO

**Set: 19**

Doors: 151

4	Hinge	TA2714 4-1/2" x 4-1/2"	626	MK
1	Classroom Lock	<u>L9071L 06A ML2055 NSA</u> <u>CT6B</u>	630	<u>SC</u> <u>RU</u>
<del>2</del>	<del>IC Mortise Interchangeable Core Cylinder</del>	<del><u>1080-114 CT6B 8000-</u></del>	626	RU
1	Protection Plate	K1050 10" 4BE	630	RO
1	Door Stop	406	630	RO
3	Silencer	608		RO



**Set: 20**

Doors: 200

3 Hinge	TA2314 4-1/2" x 4-1/2"	630	MK
1 Passage Latch	<del>L9010 06A ML2010 NSA</del>	630	<del>SCRU</del>
1 Surface Closer	4040+ <del>XP</del> EDA	AL	LC
1 Door Stop	406	630	RO
1 Threshold	As Detailed		PE
1 Rain Guard	346C		PE
1 Sweep	18062CNB		PE

**Set: 21**

Doors: 122

8 Hinge	TA2714 4-1/2" x 4-1/2"	626	MK
2 Surface Bolt	580-8	630	RO
1 Storeroom Lock	<del>L9080L 06A ML2057 NSA CT6B</del>	630	<del>RU</del> <u>SC</u>
1 <del>IC Mortise Interchangeable Core</del> CYLINDER	<del>1080-114 CT6B 8000-</del>	626	RU
1 <u>Permanent Core</u>	8000-	<del>626</del>	<del>RU</del>
1 Astragal	355CP		PE
2 Door Stop	481H	626	RO
2 Silencer	608		RO

**Set: 22**

Doors: 121

1 Pivot Set	147	626	RF
2 Intermediate Pivot	M19	626	RF
1 NS Office Lock	2190-01	630	AR
1 <u>IC Mortise</u> Cylinder	1080-114- CT6B	626	RU
1 <u>Permanent Core</u> <del>Interchangeable Core</del>	8000-	626	RU
1 Door Stop	406	630	RO
1 Gasketing	By door/frame manufacturer (Head & Jamb)		PE
2 Gasketing	ACP112BL		PE
1 Door Bottom	434ARL		PE
1 Threshold	2005AT Full Notch MSES25SS		PE

**Gensler**  
05.8010.000

~~February 8, 2013~~ July 23, 2013  
Issue for ~~DSA Backcheck~~ Addendum #001

**Ventura College**  
**Applied Science Center**  
Ventura, California

END OF SECTION 08 71 00

SECTION 27 10 00

COMMUNICATIONS CABLING

PART 1 - General

1.1 GENERAL INTRODUCTION

- A. The work shall consist of the design, provision, termination, testing and documentation of a complete and fully functional structured high performance copper and optical fiber communications cabling system. The instructions in this section are specific to communications installations and should be read in conjunction with other contract documents as applicable.

1.2 DEFINITIONS

- A. Throughout this specification, the following definitions will apply:
1. Provide: Supply, furnish, deliver, install, pull, fix, dress, terminate, label, test, ground and document the components as per these specifications.
  2. BDF (Building Distribution Frame) Rooms, are special-purpose rooms that provide space and maintain a suitable operating environment for the termination of backbone and campus cabling and house centralized communications and/ or computer equipment (such as Core Switches and Servers).
  3. IDF (Intermediate Distribution Frame), or Tele/Data Rooms are floor-serving spaces that provide a connection point between backbone and horizontal distribution pathways.
  4. Backbone Cables: Cables linking the MDF and the IDF.
  5. Horizontal Cables: Cables linking the IDF to each workstation outlet.
  6. External Cables: Cables that link the building to external connection point(s) and/or other building(s). These cables are considered to be Outside Plant (OSP).
  7. Station Cables: Cables linking workstation outlet to active equipment.
  8. Client: Ventura Community College
  9. Architect: Gensler
  10. Consultant: Vantage Technology Consulting Group
  11. Bidder: A company invited to bid for the works
  12. Installer/Contractor: The Company installing the equipment as defined in this specification

13. Construction Manager / Owner's Representative: Heery International

### 1.3 MANUFACTURER'S COMPLETE SYSTEMS

- A. The cabling system specified in this document shall be an end to end solution that is sourced from a single manufacturer or partnered manufacturers. Unless explicitly noted within these specifications, this shall include patch panels, connectors, cables, patch cords, faceplates and other associated components.
- B. Where it is specified that a system be provided by "manufacturer xxx or equal", a substitution of another manufacturer's products will only be considered for a complete end to end solution of equal quality, as determined by the Owner's Representative. All substitutions shall conform to the substitution requirements detailed in the specifications. In instances where these specifications do not include the statement "or equal" for a particular component or system, substitutions will not be entertained.

### 1.4 JOB CONDITIONS

- A. Prior to bidding visit the site and determine all existing conditions affecting work. The Bidder shall examine all drawings and specifications to familiarize themselves with the type of construction to be used, and the nature and extent of work provided by other trades.
- B. Verify dimensions and the correct location of hardware before proceeding with the installation of hardware, cabling and/or connections.
- C. Notify the Owners' Representative in writing immediately on discovery of dimensional discrepancies and other conditions detrimental to proper performance of the Work.

### 1.5 PERSONNEL

- A. The personnel who will be employed on the contract shall be suitably trained in the management of a project of this nature and/or in the installation and maintenance of products of the type being provided so as to be able to carry out all work in a competent manner.
- B. The Installer shall provide a site manager responsible for all site-related issues. This individual shall be the single point of contact for the project team and shall carry a mobile phone so they can be contacted during the working hours of the project.
- C. The Installer shall be certified by the component manufacturer(s) in the installation and testing of the cabling system and shall be able to provide a manufacturers' extended performance warranty for the 'end to end' cabling system.

### 1.6 LABELING AND NUMBERING SCHEME

- A. Labeling of the cabling system shall be in accordance with EIA/TIA 606 for the Administration of the Telecommunications Infrastructure for Commercial Buildings.

### 1.7 WARRANTY

- A. Installer to provide a warranty for one year from Notice of Completion on all materials and workmanship installed or supplied as part of the cabling system.
- B. The Installer shall also supply an extended performance warranty, as offered by the components' manufacturer(s).

#### 1.8 QUALITY

- A. The Contractor shall be responsible for the complete provision and installation of all components as specified herein. The Contractor shall provide all tools, equipment, fixtures, appliances, ancillary piece parts and hardware as necessary to complete the assembly and installation as required. The Owner's Representative may conduct scheduled or unscheduled inspections of the Contractor's work at anytime during construction. All work included in the scope assigned to the contractor that is associated with this project shall be accomplished in a workmanlike manner, installed and assembled plumb, level and square. The product shall be delivered to the Owner finished, complete, and ready to operate according to the manufacturer's specifications.
- B. All installation work shall be completed to the standard of the samples approved by the Owners Representative during the submittal process. Any products not installed to the quality detailed in these specifications and approved in the submittal process shall be reworked by the Installer to the satisfaction of the Owner's Representative at no additional cost to the Owner.

#### 1.9 STANDARDS

- A. All materials provided by the Installer shall meet the requirements of the following where applicable:
  - 1. National Electrical Manufacturer's Association (NEMA)
  - 2. American National Standards Institute (ANSI)
  - 3. Underwriters Laboratories, Inc. (UL)
  - 4. ETL
- B. All products, services and documentation provided by the Installer shall meet the requirements of the following where applicable:
  - 1. National Electrical Code (NEC)
  - 2. Relevant State Electric and Fire Codes
  - 3. ANSI/EIA/TIA 568-C.2 Commercial Building Telecommunications Wiring Standard
  - 4. ANSI/EIA/TIA 569 Commercial Building Standard for Telecommunications Pathways and Spaces

5. ANSI/EIA/TIA 606 The Administration Standard for the Telecommunications Infrastructure of Commercial Buildings
  6. ANSI/EIA/TIA 607 Commercial Building Grounding and Bonding Requirements for Telecommunications
  7. Building Industry Consulting Service International (BICSI) publications:
    - a. Network Design Reference Manual
    - b. Telecommunications Cabling Installation Manual
    - c. Customer Owned Outside Plant Design Manual
  8. Manufacturer's recommendations and installation guidelines **including but not limited to:**
    - a. Belden CSV Installation Guidelines
    - b. Chatsworth (CPI) Installation Guidelines
    - c. 3M Installation Guidelines
- C. All publications referred to in this document shall be the latest edition.

#### 1.10 SUBMITTALS

- A. All submittals shall be sent to the Construction Manager / Owner's Representative for initial processing and distribution. Three copies of each submittal should be provided unless otherwise noted. Each submittal should be provided no later than six weeks prior to the work associated with that submittal to allow time for submittal review.
- B. Project References
  1. Submit for approval, references for a minimum of three similar projects successfully undertaken and completed within the last three years. These projects should be a similar scale, complexity and have similar time scales as this project.
  2. Provide project name and address, client contact name and telephone number and construction manager name and telephone number. Provide a brief description of each project indicating types of system installed, quantities and configurations of outlets and project time scales.
  3. At least two of the references shall be located in Southern California and shall be available for the Owners Representative and other members of the Design Team to visit and inspect the installation, should, in the opinion of the Owners Representative, this be necessary.
  4. These references are intended to show that the Installer has successfully completed similar projects. Failure to produce satisfactory references may result in the bid being deemed non-compliant.

C. Personnel Training

1. Submit for approval records regarding the management, installation and testing personnel. These records shall include resumes, training certificates, previous work experience details (especially on reference projects) and other relevant information.
2. Submit records to confirm that the personnel who will be employed in an installation capacity are suitably trained in the installation and maintenance of equipment and systems of the type being provided.
3. Submit records to confirm that the personnel that will be responsible for testing the system are suitably trained in the operation of the test equipment being used in this project.
4. These records are required to ensure that the Installer is able to carry out all work in a competent manner. Failure to produce satisfactory training documentation may result in the bid being deemed non-compliant.

D. Cabling Diagram

1. Submit, for approval, a complete cabling diagram. The diagram shall be based on the singleline drawing included in the Construction Documents. It shall be updated to show quantities and part numbers for all components including patch panels, cable, conduit, cabinets and equipment racks, splices, splice cases and all other associated components.

E. Test Equipment

1. Submit, for approval, details of each item of test equipment to be used to test the optical fiber and copper components. Include patch cords and other specialized components.

F. Product Literature/Data Sheets

1. Submit for approval manufacturer's product data sheets for each component of the telephone and data cabling systems. Certify that the data sheets depict the components to be provided by the Installer to make up the complete system as described in this specification.

G. Component Samples and Mock-ups

1. Provide one full size installation sample mock-up of a normal wall faceplate for approval. All samples are to be fully labeled as per these specifications. Samples are to be delivered to the Construction Manager's office on site prior to installation.
2. All sample mock-ups are intended to represent the components that are to be installed as part of this project; therefore, they are to be provided with all associated components and labeling necessary to make up a complete mock-up. Installation shall not proceed until the Owner's Representative has approved the samples. Once samples and other documents have been submitted, inspected by the Owners' Representative and approved, they shall be retained. The samples will be used as the standards by which the quality of work on the project by the Installer shall be judged. Any installation that does not meet

this standard shall be replaced or re-worked as approved by the Owners' Representative, at no cost to the project.

- H. As-Built Documentation (required upon completion of the work)
1. Following completion of the installation, submit the following record drawings, documentation and testing for approval.
  2. As-Built Drawings
    - a. As-built drawings showing locations of telephone, Technology Rooms and data outlets, backbone, link and external cable routes, data rack locations, telephone termination board locations and station identification.
    - ~~a.b.~~ Provide laminated copies of as-builts on site in each Technology Room.
  3. Final Test Results
    - a. Test results for each cable indicating tests performed, results obtained and values measured.
  4. All documentation and drawings shall be provided in an un-locked acceptable electronic format. ~~(AutoCAD (at least R14) for drawings, MS Excel (for schedules), etc)~~ and supplied on CD-ROM or DVD-ROM.

## PART 2 - Products

### 2.1 HORIZONTAL CROSSCONNECT TERMINATED COPPER CABLING

- A. Provide Belden GigaFlex 2400 series, no equal, Category 6 UTP Cable. Each cable shall have four pairs of unshielded twisted-pair solid copper conductors. The cable shall be plenum-rated (CMP). Each cable shall meet or exceed the performance specifications in this document when installed as part of the end to end cabling system described in this specification.
- B. The high performance copper cabling system shall meet or exceed the performance specifications for Category 6 cabling as detailed in EIA/TIA 568-~~BC~~.2. This covers all Category 6 components installed as a part of the installation.
- C. Voice copper cables shall be white in color.

### 2.2 HORIZONTAL INTERCONNECT TERMINATED COPPER CABLING

- A. Provide Belden GigaFlex 3600 series, no equal, Category 6 UTP Cable. Each cable shall have four pairs of unshielded twisted-pair solid copper conductors. The cable shall be plenum-rated (CMP). Each cable shall meet or exceed the performance specifications in this document when installed as part of the end to end cabling system described in this specification.



- B. The high performance copper cabling system shall meet or exceed the performance specifications for Category 6 cabling as detailed in EIA/TIA 568-~~BC~~.2. This covers all Category 6 components installed as a part of the installation.
- C. Data copper cables shall be blue in color.

### 2.3 LINK COPPER CABLING

- A. Provide Belden, no equal, Category 6A UTP Cable. Each cable shall have four pairs of unshielded twisted-pair solid copper conductors. The cable shall be plenum-rated (CMP). Each cable shall meet or exceed the performance specifications in this document when installed as part of the end to end cabling system described in this specification.
- B. The high performance copper cabling system shall meet or exceed the performance specifications for Category 6A cabling as detailed in EIA/TIA 568-B.2. This covers all Category 6A components installed as a part of the installation.
- C. Link copper cables colors shall be verified with the Owner prior to procurement of materials.

### 2.4 OPTICAL FIBER CABLES

- A. 50/125 Micron Multimode Cable (OM4) Elements shall conform to the following specification:
  - 1. 50/125 micron multimode optical fiber cable with glass core and cladding (tolerances 50+/-3 micron, 125 +/-2 micron)
  - 2. Graded refractive index profile
  - 3. Attenuation coefficient at 850 nm of 3.5 dB/km or less
  - 4. Attenuation coefficient at 1300 nm of 1.5 dB/km or less
  - 5. Bandwidth distance product at 850 nm of 4900 MHz.km or more (laser) and 1500 MHz.km (overfilled launch)
  - 6. Bandwidth distance product at 1300 nm of 500 MHz.km or more
  - 7. Individual glass elements proof tested at 100 kpsi (100,000 lbs. per square inch)
  - 8. Number of elements as indicated on the drawings
- B. Singlemode Cable Elements shall conform to the following specification:
  - 1. 8.3 micron core diameter, 125 micron cladding diameter (+/- 1 micron)
  - 2. Mode field diameter of between 8.7 and 9.3 (with +/- 0.5 micron tolerance) at 1310 nm
  - 3. Attenuation coefficient at 1310 nm of 1.0 db/km or less
  - 4. Attenuation coefficient at 1550 nm of 1.0 db/km or less
  - 5. Cladding non-circularity of +/- 1%
  - 6. Core to cladding concentricity error of no more than 0.8 micron
  - 7. Maximum dispersion rate of 2.80 ps/nm-km at 1300 nm
  - 8. Maximum dispersion rate of 17.00 ps/nm-km at 1550 nm
  - 9. Individual glass elements proof tested at 100 kpsi (100,000 lbs. per square inch)
  - 10. Number of elements as indicated on the drawings
- C. External Cable: Provide ~~Belden~~OCC, no equal, external optical fiber cable. The cable shall be recommended by the manufacturer for use as an external cable suitable for installation in an underground duct. Optical fibers shall be contained within ~~loose-tight~~ buffered tubes utilizing

water blocking tapes or compounds surrounding these tubes. The cable will be an all-dielectric construction, with a central strength member.

## 2.5 TELEPHONE SYSTEM CABLING

- A. External Gel-Filled ASP Cable. Provide Belden, no equal, filled core telephone cable suitable for direct-burial or in-duct applications. The cable shall have solid annealed copper conductors, with a core filled with a Flex-Gel filling compound and wrapped in a non-hygroscopic core tape. The ASP sheath shall consist of a 0.008" corrugated aluminum shield, with a 0.006" corrugated steel shield and a black polyethylene jacket. The jacket shall be sequentially printed with a footage marker at regular intervals. A flooding compound shall be applied over the core and to all surfaces of the aluminum and steel shields to resist moisture entry and to inhibit corrosion. Provide printed length markings on the cable jacket every two feet. Provide the number of pairs as indicated on the drawings.
- B. External Splice Point. ~~Provide a splice closure designed for buried and underground encapsulated splices. The closure shall utilize a controlled forced injection encapsulation process, which shall force the encapsulant around the splice and down the cable core to prevent moisture from entering the splice bundle. The case shall allow all elements/cables to be dressed in without violating any manufacturer's specifications. The splice closure shall be suitable for installation in manholes, vaults and building entrance applications. The closure shall provide mechanical support for the splice. Provide encapsulant, 710 modules, splice connectors and all associated components. Utilize existing splice closures in Vault T6 provided as part of previous site preparation project.~~
- C. Internal Splice Point. Provide a splice enclosure suitable for internal use. The splice case shall be sealed to be moisture and vermin resistant. The case shall allow all elements/cables to be dressed in without violating any manufacturer's specifications. The splice closure shall be suitable for installation in building entrance applications and shall be properly grounded. The closure shall provide mechanical support for the splice. Provide 710 modules, splice connectors and all associated components. Provide 3M SLIC closures, no equal..

## 2.6 TELEPHONE SYSTEM TERMINATION FRAMES

- A. Rack- Mounted BIX Wiring Blocks. Provide Belden, no equal, rack-mounted BIX wiring blocks. The blocks shall be sufficient to accommodate the backbone and horizontal voice cables throughout the project and also include vertical cable managers.

## 2.7 WORK AREA CONNECTORS

- A. Provide Belden GigaFlex PS6+, no equal, eight-position modular RJ45 jacks. Each connector shall meet or exceed the channel performance specifications in this document when installed as part of the end to end cabling system described in this specification. The pin outs for the jack shall conform to the T568B wiring scheme.

B. Work area connectors shall be white for voice and blue for data.

B-C. Provide additional 25% spare work area connectors.

## 2.8 PATCH PANELS

- A. Data Patch Panels. Provide Belden GigaFlex PS6+, no equal, Patch Panels (AX101613) conforming to the following specification:
1. Suitable for mounting in standard EIA 19" racks.
  2. Configured with 48 jacks housed in each 2U (3.5") of usable rack space.
  3. Provide strain relief for each cable terminated on the connector at the rear of the patch panel.
  4. Allow for labeling of each individual connector.
  5. Allow any individual cable to be terminated or otherwise handled without disturbing other cables.
- B. Link Patch Panels. Provide Belden Key Connect no equal, Modular Patch Panels conforming to the following specification:
1. Suitable for mounting in standard EIA 19" racks.
  2. Configured with 48 jacks housed in each 2U (3.5") of usable rack space.
  3. Provide strain relief for each cable terminated on the connector at the rear of the patch panel.
  4. Provide Category 6A connectors, colors to be verified with Owner, for each cable installed.
  5. Allow for labeling of each individual connector.
  6. Allow any individual cable to be terminated or otherwise handled without disturbing other cables.
- C. Rack Mounted Optical Fiber Patch Panel. Provide Belden FiberExpress optical fiber patch panel, conforming to the following specification:
1. Each panel shall be suitable for installation in EIA 19" mounting frame.
  2. Configured with 72 connectors housed in each 4U (7") of usable rack space.
  3. Allow for labeling of each individual connector.
  4. Allow any individual cable to be terminated or otherwise handled without disturbing other cables.
  5. Each panel shall provide fiber handling for fiber elements, including 36" fiber reserve (service loop) inside the patch panel with no bends sharper than 2" bend radius.
  6. Provide blanking adapter plates to cover all unused spaces as necessary.

7. Belden FiberExpress Manager Connector Module with Metal Sleeve, multimode 12 fibers (LC duplex).
8. Belden FiberExpress Manager Connector Module with Zirconia ceramic, singlemode, 12 fibers (LC duplex).
9. Belden Field Breakout Kit
10. Belden Blank Adapter Panel

D. Provide 25% additional capacity in patch panels.

## 2.9 OPTICAL FIBER CONNECTORS

A. Multimode Optical Fiber Connectors. Provide Belden 3M Hot Melt, no equal, LC OM4 multimode optical fiber connectors, conforming to the following:

1. Duplex, handling one pair (two elements) per connector.
2. Beige in color.
3. Compatible with both 900 micron buffered strands and 250 micron loose tube strands.
4. Maximum insertion loss, of mated pair, less than 0.5 dB at acceptance.
5. Minimum return loss of greater than or equal to 20 dB.
6. Durability better than 500 matings, with a maximum increase in insertion loss of not more than 0.2 dB.
7. Meets ANSI/TIA/EIA 568-B and ISO 11801 standards.

B. Singlemode Optical Fiber Connectors. Provide Belden 3M Hot Melt, no equal, LC optical fiber connectors, conforming to the following specification.

1. Duplex, handling one pair (two elements) per connector.
2. Blue in color.
3. Compatible with both 900 micron buffered strands and 250 micron loose tube strands.
4. Maximum insertion loss, of mated pair, less than 0.5 dB at acceptance.
5. Minimum return loss of greater than or equal to 50 dB.
6. Durability better than 500 matings, with a maximum increase in insertion loss of not more than 0.2 dB.
7. Meets ANSI/TIA/EIA 568-B and ISO 11801 standards.

~~2.10~~ ~~PATCH AND STATION CABLES~~

- ~~A. The patch cords and station cables listed below are to be passed to the client on completion of the project. Each cord is to have a manufacturer's certificate of conformance and shall be in its original, unopened packaging.~~
- ~~B. Provide (2) Belden, no equal, high performance copper patch cords / station cables for 75% of all ports installed. Each cord shall meet or exceed the performance specifications in this document when installed as part of the end to end cabling system described in this specification.~~
- ~~1. Voice copper patch cords shall be 4' - 15' as required by the Owner, white in color, and configured to patch from BIX block to switch~~
  - ~~2. Data copper patch cords shall be 4' - 15' as required by the Owner, blue in color, and configured to patch from patch panel to switch~~
  - ~~3. Link copper patch cords shall be 4' - 15' as required by the Owner, color verified by Owner, and configured to patch from patch panel to switch~~
- ~~C. Optical Fiber. Provide one LC-LC optical fiber patch cord per optical fiber pair installed. These shall be sourced from the same manufacturer as the optical fiber connectors provided as a part of this project. Each cord shall meet or exceed the optical fiber performance specifications in this document.~~
- ~~1. 20% of the patch cords shall be 3 feet in length and aqua in color for multimode and yellow in color for singlemode~~
  - ~~2. 60% of the patch cords shall be 7 feet in length and aqua in color for multimode and yellow in color for singlemode~~
  - ~~3. 20% of the patch cords shall be 11 feet in length and aqua in color for multimode and yellow in color for singlemode~~

~~2.11~~ 2.10 WORK AREA FACEPLATES

- A. Wall-mounted Faceplate. Provide a Belden MediaFlex (P/N: AX101747); no equal, wall-mounted flush modular faceplate to house work area jacks, capable of housing a minimum of four jacks. The faceplate shall fit over a standard NEMA electrical outlet box fitted with a single gang plaster ring cover and shall be office white in color.
- B. Blanking Inserts. Provide blanking inserts, matching faceplates, in sufficient quantities to cover all unused openings in every faceplate.
- C. Wallphone Faceplate. Provide a Belden MediaFlex, no equal, wall-mounted flush modular faceplate to house a single work area jack. The faceplate shall fit over a standard NEMA electrical outlet box fitted with a single gang plaster ring cover. The faceplate shall be capable of having a wall-mounted telephone fitted directly over it.

- D. Furniture Faceplate. Provide a Belden MediaFlex, no equal, flush-mounted modular faceplate to house work area jacks. The faceplate shall fit over a modular raceway.
- E. Floorbox Faceplate. Provide an internal blank bracket to house combinations of work area connectors in a flush-mounted floorbox. The bracket shall be provided by the manufacturer of the flush floorbox and shall be designed to fit in the floorbox installed as a part of this project.

#### 2.122.11 LABELS

- A. Provide labels for connectors, cables, outlets, termination frames and patch panels.
- B. The lettering on each label shall be as large as is practicable. All labels shall be machine-produced. Hand-written labels will not be acceptable.
- C. A standard relative orientation shall be adopted for all labels unless otherwise specified.
- D. Labels shall be robust, durable, shall resist abrasion and shall be UV inhibiting, permanent and indelible. Labels shall be proof to 140 degrees Fahrenheit.
- E. All labels shall be readily visible and shall be fixed so that they remain in a visible position wherever practical.
- F. Labels shall carry the full complement of characters to designate the unique identifications for the item that they identify.

G. ~~The patch panel and~~ faceplate labels are to be a white and black ~~engraved plastic sandwich material~~ laser or thermal printed label, i.e. black letters on white background. Labels are to be placed below the clear plastic lens on the Mediaflex face plate.

~~G.H.~~ —The patch panel labels are to be a white and black adhesive-backed nylon thermal printed labels, i.e. black letters on white background. Labels are to be placed below the clear plastic lens on the Mediaflex face plate.

~~H.I.~~ The Patch Panel labels shall be permanently fixed to the patch panel front cover with an epoxy adhesive

~~H.J.~~ Cable Labels

1. Provide self-laminating wrap labels for cables with less than ½" diameter. The labels shall permanently fixed to each cable once they have been installed. Any labels that split, partially split or otherwise damaged shall be replaced.
2. Horizontal Cabling: Label each cable so that the label is within 8" of the end of the cable at the patch frame end and within 6" of the end of the cable at the outlet end.

#### 2.132.12 EQUIPMENT RACKS

- A. Provide CPI 46353-703, no equal, as shown on the Drawings. Each rack shall conform to the following specification:

1. Each rack shall consist of a modular EIA 19" mounting frame, with a minimum of 84" (45U) space for equipment in the vertical plane.
2. Provide all mounting components and accessories to securely fix racks to floor and supporting walls. Provide appropriate seismic transverse and longitudinal bracing per any local codes and the current NUSIG (National Uniform Seismic Installation Guidelines).
3. Provide overhead ladder rack, CPI 10250-718, no equal, fixed to the top of each rack and running from the top of the rack to the telephone backboard where the feeder and horizontal cables run, as shown on the drawings.
4. Provide cable bend management fixtures to maintain the proper bend radius as the cables drop into the rack. Do not allow cables to be unsupported as they run from conduit or cable tray to equipment cabinets.
5. Provide appropriate seismic bracing brackets for anchoring the cabinets on raised floor. Use a minimum of 5/8" threaded rod and appropriate concrete drop-in anchors for securing the cabinets above on the raised floor. The 5/8" threaded rod shall be further secured with aircraft cable per any local codes and the current NUSIG (National Uniform Seismic Installation Guidelines).
6. Each rack shall have a load-carrying capacity of 1000 lbs.
7. Provide patch management ring runs in each rack. Provide (1) 2U front-side horizontal patch management in the top and bottom of each rack and top and bottom of each 4RU worth of patch panel-s – CPI 30530-719, no equal. Provide two-sided CCS type vertical cable management with hinged doors on both sides of each rack – CPI ~~30095-703 and 30094-703~~ 30162-703, no equal.
8. Provide strain relief and cable management at the rear of each rack to ensure tidy routing of all feeder and horizontal cables.
9. The rack shall be manufactured from extruded aluminum and black in color.

#### 2.142.13 EQUIPMENT CABINETS

- A. Provide CPI Megaframe, no equal, Equipment Cabinets as shown on the Drawings. Each cabinet shall conform to the following specification:
  1. Each cabinet shall house two 19" internal mounting frames. Each pair of mounting rails shall be depth adjustable for front and rear equipment support. Cabinet shall be 32" wide by 42" deep.
  2. Each cabinet to provide a minimum of 84" (45U) space for equipment in the vertical plane.
  3. Each cabinet shall have a minimum load-carrying capacity of 2500 lbs.

4. Provide grommated openings at the top of each cabinet requiring top access. The openings shall be a series of 4" diameter holes with bushings. The openings shall allow the cables to easily enter the cabinet and be routed into the cabinet cable management.
5. Provide all mounting components and accessories to securely fix cabinets to floor. Provide appropriate seismic transverse and longitudinal bracing per any local codes and the current NUSIG (National Uniform Seismic Installation Guidelines).
6. Provide cable bend management fixtures to maintain the proper bend radius as the cables drop into the cabinet. Do not allow cables to be unsupported as they run from conduit or cable tray to equipment cabinets.
7. Each cabinet to have a lockable perforated metal front door, lockable double perforated metal rear doors, and two solid side panels.
8. Provide Velcro cable straps, at the front of the cabinet, to each side, to manage patch cords, every 5U on both sides of each rack.
9. Provide cable supports, to each side, at rear to loom fixed cable terminations
10. Provide (1) 2U front-side horizontal patch management in the top and the bottom of each cabinet and top and bottom of each patch panel CPI 30530-719, no equal. Each cabinet shall be equipped with at least one internal vertical cable manager designed for the selected system.
11. All other parts needed to make the cabinet into a usable system shall be provided. These parts include appropriate bolts, installation kits, and mounting equipment for items specified.

#### 2.152.14 AUDIOVISUAL EQUIPMENT RACKS

- A. Provide Middle Atlantic Equipment Cabinets as shown on the Drawings. Each cabinet shall conform to the following specification:
  1. Gang-able rack enclosures shall be used in locations where two or more racks are grouped together. Height and quantity as indicated on drawings. Unless otherwise specified, the enclosure depth shall be 36" minimum. Finish shall be black powder coat. Acceptable: Middle Atlantic series WRK, or comparable by CPI, Atlas Sound, Lowell, or Stantron.
  2. Provide the accessories noted below for each gang-able rack enclosure. All accessories shall be from the same manufacturer as the rack enclosure.
    - a. Side panels (for end racks of each group of racks)
    - b. Cable chase (as required)
    - c. Vented top and solid rear door
    - d. Grounding stud in top rear of rack
    - e. Forced air ventilation configured for equipment and heat loads
    - f. Full height rear mounting rails
    - g. Full height solid copper bus bar bonded to rack
    - h. Rack work light



- i. Horizontal lacing bars (as required)
  - j. Seismic base and support
  - k. Switched & circuit protected vertical power strip(s)
3. Stand-alone rack enclosures shall be used in locations where single racks are specified. Height and quantity as indicated on drawings. Unless otherwise specified, the enclosure depth shall be 32.5" minimum. Finish shall be black powder coat. Acceptable: Middle Atlantic series WRK-SA, or comparable by Atlas Sound, Lowell, or Stantron
  4. Provide the accessories noted below for each stand-alone rack enclosure. All accessories shall be from the same manufacturer as the enclosure.
    - a. Solid top and solid rear door
    - b. Grounding stud in top rear of rack
    - c. Forced air ventilation configured for equipment and heat loads
    - d. Full height rear mounting rails
    - e. Full height solid copper bus bar bonded to rack
    - f. Rack work light
    - g. Horizontal lacing bars (as required)
    - h. Caster base or seismic base
    - i. Switched & circuit protected vertical power strip(s)

#### 2.162.15 CABLE SUPPORTS

- A. Provide J-Hooks to support communications cables running in the ceiling void in locations where cable tray and/or conduit is not provided. J-Hooks to be B-Line, Mono Systems 'The Hook', Caddy 'Cable Cat' or equal.

### PART 3 - EXECUTION

#### 3.1 HORIZONTAL CABLING AND COMPONENTS

##### A. Horizontal Cabling

1. Provide one four-pair high performance plenum-rated horizontal cable running from each work area connector to the patch panels located in the Technology Room serving that outlet. Terminate all four pairs of each end of each cable with an RJ45 communications connector using the EIA/TIA 568B.2 termination scheme.

##### B. Work Area Outlets

1. Standard Work Area Outlet. Each standard work area outlet will be a wall-mounted flush modular faceplate configured with (4) RJ45 connectors, unless otherwise noted. The faceplate shall fit over a deep NEMA electrical outlet box fitted with a single gang plaster ring cover and shall match the electrical faceplate color. Any unused faceplate opening shall contain a matching blanking insert.
2. Wall-phone Outlet. Each wall-phone outlet will be a wall-mounted flush modular faceplate to house a single (1) RJ45 connector. The faceplate shall fit over a deep NEMA

electrical outlet box fitted with a single gang plaster ring cover and be capable of having a wall-mounted telephone fitted directly over it.

3. Furniture / Raceway Outlet. Each Furniture outlet will be a flush-mounted modular faceplate to house (4) RJ45 work area jacks as shown on the drawings. The faceplate shall fit over a modular raceway.
4. Floorbox Outlet. Each Floorbox outlet will be a flush-mounted modular faceplate to house (4) RJ45 work area jacks as shown on the drawings.

### 3.2 OPTICAL FIBER AND HIGH PERFORMANCE COPPER LINK CABLING

#### A. High Performance Copper Link Cable

1. Provide Category 6A high performance 4-pair cables running between each of the Telecommunications Rooms, as shown on the drawings. The high performance cables shall not exceed 90 meters.
2. Terminate all four pairs of each end of each cable with an RJ45 communications connector fitted in a rack-mounted patch panel using the EIA/TIA 568B termination scheme. Label each connector with the link cable number.

### 3.3 EXTERNAL CABLING AND COMPONENTS

#### A. Copper Cabling

1. Provide external telephone cable running from the Communications Manhole #6 to the Telecommunications Room, as shown on the drawings.
2. ~~Provide~~ Utilize existing external splice case in Communications Manhole #6 and splice new multi-pair copper cable to existing multi-pair copper cables utilizing 710 splice modules, quantities as shown on the drawings. Properly ground and bond copper cables and splice case. Provide encapsulate as needed.
3. Upon entering Telecommunications Room, provide an internal splice case. Splice external copper cable to internal copper cable utilizing 710 splice modules, quantities as shown on the drawings. Properly ground and bond copper cables and splice case.
4. Extend internal copper cable from splice case to rack-mounted BIX wiring blocks. Terminate, test, and label each copper pair.

#### B. Optical Fiber Cabling

1. Provide external optical fiber running the Telecommunications Room to the MDF in the Student Services building, as shown on the drawings. Contractor shall use existing innerduct running from the Communications Manhole #6 to the MDF. Terminate each pair of optical fiber elements with the same optical fiber connectors used for the backbone cabling system, fitted in an optical fiber rack-mounted patch panel. Label each connector with the backbone cable number.

2. Provide patch panels fitted in the equipment cabinet, racks, and/or wall-mounted as shown on the drawings, to house optical fiber cables terminated on optical fiber connectors.
3. Securely fix all patch panels in place.
4. Provide a sufficient number of patch panels to house all specified optical fiber cables and connectors.
5. Terminate all elements of each optical fiber cable with the specified connectors. Strip back the optical fiber cable jacket, providing a 36" service loop for each optical fiber element. Neatly dress these loops in the patch panel using appropriately sized spiral wrap, so they are protected.

### 3.4 TECHNOLOGY INFRASTRUCTURE

#### A. Data system equipment cabinets and racks

1. Provide equipment cabinets and racks, as shown on the drawings.
2. Securely fix the cabinets/racks in place.
3. Whenever cables are to enter the cabinets from above, provide a 12"x6" grommeted opening on the top of the cabinet.
4. Attach the power strip to the cabinet/rack. Ensure that the power strips are connecting to the cabinets/racks in such a way that the structural integrity of the cabinets/racks is not compromised. Connect the cabinet power strip to an appropriate power receptacle.
5. Fix each cabinet and rack to the floor and supporting walls to provide stability and prevent movement of the cabinet or rack. Fix adjacent racks and cabinets together.
6. Install the appropriate seismic transverse and longitudinal bracing per any local codes and the current NUSIG (National Uniform Seismic Installation Guidelines).

#### B. Conduit, Ladder Rack And J-Hook Installation

1. Where shown on the drawings, provide solid metal conduit to protect cable runs. Securely fix this conduit to structural elements at regular intervals. Provide couplings, end pieces, grommets and associated components to make up a complete conduit run. All conduit installation shall be done in accordance with the relevant NEC regulations. No L-bends (condulets) are to be installed; any bends in the conduit runs are to be provided using sweeps.
2. Where cables are installed in an open cabling method (i.e. J-Hooks) and encounter full height partitions or other obstructions, Contractor shall provide conduit sleeves. Conduits sleeves shall be sized and fire-stopped per all applicable national and local electric and fire codes.

3. Ladder rack. Where shown on the drawings, provide metal ladder rack to support equipment racks and route communications cabling.
4. J-Hooks. Where conduit or cable tray is not provided to support cable runs, provide J-Hooks fastened to the structural slab at 48" centers. J-Hooks shall not be attached to beams, ceiling tile tee grid or wire hangers used to support the ceiling grid. J-Hooks shall be attached to the slab using anchors and ¼" rod used exclusively for supporting J-Hooks. J-Hooks can be fixed to stud walls provided the cable load is no more than 10lbs per stud.
5. Install the appropriate seismic transverse and longitudinal bracing per any local codes and the current NUSIG (National Uniform Seismic Installation Guidelines).

C. Innerduct

1. Provide innerduct to protect optical fiber cable runs. Securely fix the innerduct to structural elements at 36" centers. Provide couplings, end pieces, grommets and associated components to make up a complete innerduct run. The innerduct shall be a suitable fire rating for the installed environment.

D. Communications Manholes

1. Provide a 12' service loop for each external cable that passes through a communications manhole. Dress the cable to keep it clear from any water that may be in the bottom of the manholes and to minimize any risk of damage caused by later visits to the manhole.

### 3.5 INSTALLATION PRACTICE

- A. Provide bushings, grommets and strain-relief for cables terminating at wall-mounted outlets and patch panels to ensure durable and robust connections. The bushings and grommets are intended to protect the cables from any sharp edges that present a risk to the cables. Ensure that all sharp edges are covered to protect the cables from damage.
- B. No cables shall be installed in a fashion that contravenes either the minimum installed or the minimum under-load bend radius of the cable.
- C. No cable is to be pulled through a conduit "L-bend" (condulets). In existing routes with L-bends, the cables are to be pulled to the L-Bend. The cable is then to be carefully pulled through the remainder of the conduit run.
- D. Install all cables in complete runs from outlet or patch panel to patch panel. In-line joints, splices, distribution points or other intermediate connections are not permitted unless specifically called out by this specification.
- E. At no point shall the communications cables be tied to power cables or other building services or their supports, or run in the same ducts, raceways, conduits or connection boxes as power cabling.
- F. Use plenum-rated ~~tie~~ Velcro tie wraps in plenum spaces.

- G. Reinstate all pull-wires in conduits and ducts after use to facilitate future addition of cables.
- H. Cables shall not be held so tightly with cable ties that the cable jackets are indented by the cable ties.
- I. Ensure that all waste materials are disposed of in a safe manner. Pay particular attention to waste materials produced during the termination of optical fiber cabling. Ensure that all used components and fiber cut-offs are collected in purpose-made containers and disposed of properly.
- J. Replace all moisture and fire barrier material in ducts, conduits and other penetrations disturbed during installation of communications cabling. Install barrier material in all fire-rated penetrations that have cabling running through them. The barrier material shall be installed so the final penetration has the same fire rating as the original wall/floor.
- K. Use purpose-built pulling grips during cable installation. Do not pull cables by attaching pull wires to cable jackets, elements or reinforcement. Use strain gauges or equivalent measures to ensure that the maximum tensile load rating of the cables is not exceeded during installation.
- L. Provide J-hooks and cable hangers as necessary to support cables running in the ceiling void. J-hooks shall be appropriately sized to allow a minimum of 50% spare capacity for future cable installation. J-hooks shall be at least 1" wide, and fitted at no more than 48" centers.
- M. The number of cables in each conduit shall be controlled to allow for future cable installation and to stay within the manufacturers maximum allowable cable pulling tension. Conduit fill ratios shall not exceed the current requirements of the NEC.
- N. The maximum run length of each horizontal cable shall not exceed the 90m (~295ft) limit specified by EIA/TIA 568-B.2. Notify the Owner's Representative immediately if, due to on-site conditions or other factors, a horizontal cable run length exceeds this distance.
- O. Provide Velcro hook and loop ties to secure cabling running in the Telecom Closets. Provide straps at 3' intervals. On completion of installation, neatly run and re-tie all cable bundles in the Closet.
- P. All cable bundles exiting floor or wall penetrations and running into furniture or casework shall be wrapped in spiral wrap or split-loom tubing to protect the cabling and provide a neat installation.
- Q. Labels shall be machine generated, not hand written, and placed within 12 inches of each end of each cable.

### 3.6 UNUSED COMPONENTS

- A. Any components purchased in accordance with these specifications and unused shall be documented and passed to the owner on completion of the project.

### 3.7 TESTING

A. General Instructions.

1. The testing is to show beyond reasonable doubt that there are no errors, damaged or incorrectly installed components, that the installation is correctly labeled and that all the installed components meet or exceed the criteria detailed in these specifications. Any test that does not show that a component is satisfactorily installed, as per these specifications, shall be repeated. If a test procedure needs to be modified to satisfactorily test some components, the modification shall be submitted for approval of the Owner's Representative, prior to the tests being conducted.
2. Following optical fiber and data cable installation, including labeling and termination at both ends, undertake and record tests to ensure that the cabling system will perform satisfactorily in service. In addition to the tests detailed in this specification, the Installer shall carry out any additional tests that the Installer deems necessary to ensure the satisfactory operation of the telephone and data systems. The costs of these additional tests shall be borne by the Installer.
3. All outlets, cables, patch panels and associated components shall be fully assembled and labeled prior to testing. Any testing performed on incomplete systems shall be redone on completion of the work.
4. Provide the Owners' Representative with the opportunity to witness all testing. On reasonable request, the installer shall demonstrate that the test procedure competently identifies the fault conditions being tested for.
5. Complete all of the tests identified in these specifications.
6. Notify the Owners' Representative ten working days before the date of commencement of the cable tests. Provide details in writing, on that advance date, of proposed tests, the test schedule, equipment to be used, its certification and calibration and the names and qualifications of test personnel.
7. The Owner and Owners Representative shall be invited, to the first instance of each type of test conducted. In the event of a number of tests being conducted by the Installer prior to this first inspection, the Owner's Representative reserves the right to reject these tests as non-compliant and to require them to be repeated at the Installer's cost.
- 7-8. The owner will reserve the right to request the use of the specific tester used by the contractor to conduct a random test of approximately 5% of the installed cables. If the measurement results differ appreciably (+/- 20%) from those of the contractor provided report than the sample will be expanded to 20% and be re-tested by the contractor under the observation of the customer. If the variances continue than the customer reserves the right to request a 100% re-test of the installation by a mutually agreeable third party, at the expense of the contractor.
- 8-9. Include the cost of obtaining, calibrating and maintaining test equipment and the cost of carrying out and recording the tests detailed in this specification, including labor costs, in the bid sum. No extra costs will be entertained.

~~9.10.~~ Ensure that all test equipment is in calibration before delivery to site and throughout the testing period. The Installer shall be responsible for ensuring that any necessary tests and rework to maintain equipment's calibration status is carried out. Any tests performed on uncalibrated test equipment shall be repeated at the Installer's cost.

~~10.11.~~ The test documentation shall be available for inspection by the Owners' Representative during the installation period and copies shall be passed to the Owners' Representative within five working days of completion of tests on cables in each area. The Installer shall retain a copy to aid preparation of as-built information.

~~11.12.~~ Failures detected during the testing shall be noted on the test results schedule, rectified and re-tested. On the fault being rectified, this shall also be noted. These notes shall not be deleted or obliterated.

~~12.13.~~ Rectification of all damaged cables shall include replacing damaged cables with new cables in complete runs, replacing damaged connectors or remaking poor terminations. In-line cable joints, splices or distribution points will not be acceptable except where specified in this document. All damaged cables shall be removed from site.

~~13.14.~~ If on submittal of the As-Built documentation there are any missing test results or incorrectly named files, the test shall be repeated at the Installer's expense.

B. Telephone System External and Backbone Cabling

1. Test each Telephone System Backbone and External Cable and its associated patch frame connectors. Carry out the following tests on every pair of every telephone system feeder and external cable:

- a. Wire map
- b. Length
- c. Insertion Loss

C. Category 6/~~6AA~~ Cabling

1. Test each Category 6/~~6AA~~ Cable and its associated connectors. Carry out the following tests on every pair of every Category 6/~~6AA~~ cable:

- a. Wire Map
- b. Length
- c. Insertion Loss
- d. NEXT Loss
- e. FEXT Loss
- f. ELFEXT

- g. Propagation Delay and Delay Skew
  - h. Return Loss
  - i. Power Sum Near-End Crosstalk (PSNEXT) Loss
  - j. Power Sum Equal Level Far-End Crosstalk (PSELFEXT)
- D. Work Area Faceplates and Blanking Plates
- 1. Carry out a visual inspection of the faceplates and blanking plates. Replace all damaged components.
  - 2. Ensure that all faceplate labels are installed correctly.
- E. Optical Fiber Cabling
- 1. Test each Optical Fiber Cable and its associated connectors. Carry out the following tests on every element of every optical fiber cable:
    - a. Length
    - b. End-to-End Attenuation
    - c. Connector Loss
    - d. Splice Loss
    - e. Power Loss
  - 2. The tester shall have the following parameters:
    - a. Optical Time Domain Reflectometer (OTDR) shall be used to test every optical fiber cabling
    - b. OTDR shall be used to test optical in both directions and take the average. Provide a launch lead and far end drop off lead.
    - c. Multimode optical fibers shall be tested at 850nm and 1300 nm. Singlemode optical fibers shall be tested at 1310nm and 1550nm
  - 3. Test each optical fiber cable element and its associated connectors. Carry out the following test on every element of every optical fiber cable:
    - a. Visually check optical connectors using microscope (minimal magnification x200) to ensure that no physical damage has occurred during the installation process. There are to be no scratches on the core of the fiber or pits on the core or cladding. If any defect cannot be rectified with polishing, the connector is to be replaced.



- b. Carry out OTDR tests on all elements at 1300nm wavelength for multimode cable runs and at 1310 nm for singlemode. These tests shall be carried out from both ends using a near end launch lead and a far end drop lead.
- c. The number of samples (averages) for each OTDR test shall be such that the noise amplitude is significantly less than the smallest loss of any component under test. This may vary for different cable runs, for shorter runs and fusion splices etc.; it may be necessary to run many samples.
- d. Record the length and loss of each mated connector pair on the test results schedule for all elements.
- e. Verify the labeling of the cable and connectors is correct.
- f. If a element has an excessive attenuation coefficient, a sudden step in attenuation coefficient (greater than 0.2 dB) or back scatter, losses due to micro bending or macro bending or has any other fault then the fault on that element shall be rectified.
- g. The following table lists the pass/fail criteria for all connectors and fusion splices under test. Any component that does not pass these figures shall be re-worked or replaced.

Element Type	Maximum at-tenuation across mated connector pair (dB) – outward test	Maximum at-tenuation across mated connector pair (dB) – return test	Maximum Attenuation across fusion splice – averaged over both directions(dB)	Minimum Return Loss (dB) – outward test	Minimum Return Loss (dB) – return test
<b>MM</b>	<b>0.7</b>	<b>N/A</b>	<b>0.1</b>	<b>N/A</b>	<b>N/A</b>
<b>SM</b>	<b>0.5</b>	<b>0.5</b>	<b>0.1</b>	<b>36dB</b>	<b>36dB</b>

- h. The attenuation of each multimode connector shall be measured in one direction (outward). The attenuation of each singlemode connector shall be measured in both directions.
- i. Each fusion splice shall be tested in both directions for both multimode and singlemode elements. The measurements for each direction shall be averaged for the final attenuation figure for each fusion splice.
- j. The return loss must be measured in both directions for singlemode connectors. The return loss shall be greater or equal to the value shown in the table above.
- k. Any failures shall be recorded (including value of excessively lossy terminations) and the results obtained after rectification of the fault shall be recorded.
- l. Graphical printouts shall be taken of OTDR tests for each element. These printouts shall be stapled or otherwise attached to 11" x 8.5" size sheets. They shall be printed at an appropriate scale, such as 0.5 dB per division for the

attenuation axis. Provide diskette copies of the OTDR traces to the owner on completion of the testing. Provide a copy of the emulation software and the appropriate license to the client.

END OF SECTION 27 10 00

## CONTROL EQUIPMENT SCHEDULE

ALL EMS CONTROL MODULES SHALL BE AUTOMATED LOGIC CORP.

GW  
1

GATEWAY ROUTER - LGR. TO BE MOUNTED IN THE COMMUNICATION ROOM. COORDINATE WITH CAMPUS IT FOR LOCATION AND IP ADDRESS PROVIDE PATCH CABLE FROM MODULE TO POC TO NETWORK

CM  
1

CONTROL MODULE - SE SINGLE UNIT CONTROLLER WITH SIX DIGITAL OUTPUTS, SIXTEEN UNIVERSAL INPUTS AND SIX ANALOG OUTPUTS. INSTALL IN NEMA 3R ENCLOSURE AT UNIT

CM  
2

CONTROL MODULE - ZN220 EXHAUST FAN, SPLIT SYSTEM CONTROLLER WITH TWO DIGITAL OUTPUTS, TWO UNIVERSAL INPUTS. INSTALL IN NEMA 3R ENCLOSURE AT FAN

TH  
1

ZONE SENSOR - ALC RS PRO TIMED LOCAL OVERRIDE, SET POINT ADJUST AND COMMUNICATION JACK. DIGITAL DISPLAY.

TH  
2

ZONE SENSOR - ALC RS STANDARD. FLUSH MOUNTED TEMP SENSOR.

TH  
3

LINE VOLTAGE THERMOSTAT AT ELECTRICAL ROOM. SEE SCHEDULE ON MO.01

TH  
4

SPLIT SYSTEM THERMOSTAT BY MANUFACTURER

DT  
1

DUCT TEMP SENSOR - BAPI MODEL BA/10K-2-D-12", DUCT MOUNTED TEMPERATURE SENSOR WITH INTEGRATED HANDY BOX. USED FOR SUPPLY & RETURN AIR TEMP.

OT  
1

TEMP & HUMIDITY SENSOR - BAPI MODEL BA/10K-2-H210-0-EU WITH INTEGRATED EXTERIOR BOX. BAPI.

CS  
1

CURRENT SENSOR - 0-5VDC OR 4-20mA OUTPUT CURRENT SENSOR, AT AC-1 A&B INDOOR FAN & EXH. FANS DETERMINE MOTOR AMPERAGE AND STATUS. VERIS INDUSTRIES OR NIELSEN KULJIAN

PS  
1

PRESSURE SENSOR FOR BUILDING PRESSURIZATION, CONTROLS POWER EXHAUST. VERIS INDUSTRIES MODEL PX OR EQUAL. MAINTAIN POSITIVE 0.02 TO 0.04" WC. LOCATE ABOVE CEILING IN ZONE AREA.

CO2  
1

CARBON DIOXIDE SENSOR. BAPI MODEL BA/B53 WITH TEMPERATURE

WS  
1

WALL SWITCH. LEVITON OR EQUAL. TO SHUT OFF THE AIR CONDITIONING FUNCTION WITH USER INPUT

FS  
1

FILTER STATUS AT EACH ROOFTOP UNIT. DIFFERENTIAL PRESSURE SENSOR VERIS INDUSTRIES MODEL PX OR EQUAL

### NOTES:

- HARDWIRE THE SMOKE DETECTOR FOR UNIT SHUTDOWN UPON SMOKE DETECTION PROVIDE EMS MONITORING OF SMOKE DETECTOR STATUS.
- INSTALL ALL WIRING IN CONDUIT.
- SEE PROJECT SPECIFICATIONS FOR SEQUENCE OF OPERATIONS.
- AC 1&4, 5, 7 HAVE DUAL THERMOSTATS AND CO2 SENSORS THAT SHALL BE AVERAGED.
- DURING OWNER TRAINING CYCLE UNITS THROUGH ALL FUNCTIONS.
- WIRE REMOTE POWER EXHAUST TO UNIT WITH MANF. SUPPLIED HARNESS

## EMS CONTROL POINTS

AC 1-7  TYP

### INPUTS

SUPPLY AIR TEMPERATURE  
RETURN AIR TEMPERATURE  
RETURN AIR HUMIDITY  
MIXED AIR TEMPERATURE  
FAN STATUS  
UNIT ALARM  
OUTSIDE AIR TEMPERATURE - ONE UNIT ON BUILDING  
HUMIDITY - ONE UNIT ON BUILDING

DUCT DETECTOR STATUS (SEE NOTE 1 FOR WIRING)

THERMOSTAT (TWO EACH AT AC-1, 2, 4, 5)

ROOM PRESSURE SENSOR

CO2 SENSOR (TWO EACH AT AC-1, 2, 4, 5)

AC-4 - AIR CONDITIONING SHUT-OFF SWITCH

FILTER STATUS SENSOR

### OUTPUTS

FAN ENABLE  
STAGE 1 COOLING  
STAGE 2 COOLING  
STAGE 1 HEATING  
STAGE 2 HEATING  
ECONOMIZER POS.  
POWER EXHAUST

## EXHAUST FAN 1



INPUTS  
FAN STATUS

OUTPUTS  
ENABLE

## SPLIT SYSTEM SS-1





INPUTS  
TEMPERATURE MONITOR

## SPLIT SYSTEM SS-2





INPUTS  
TEMPERATURE MONITOR  
DUST SENSOR AT SUPPLY & RETURN

## REVISED EXHAUST FAN SCHEDULE

EF  
3

EXHAUST FAN. GREENHECK MODEL G-097-VG. 140 CFM @ 1.2" WC. ELEC. DATA - 110/1/60, 1/4 HP. WEIGHT 61 LBS. SPEED CONTROL AT MOTOR. CONTROL WITH MOTOR RATED SWITCH NEXT TO HOOD. BENCH AT LOCATION SHOWN. WITH ROOF CURB.

EF  
4

EXHAUST FAN. GREENHECK MODEL G-097-VG. 140 CFM @ 1.2" WC. ELEC. DATA - 110/1/60, 1/4 HP. WEIGHT 61 LBS. SPEED CONTROL AT MOTOR. CONTROL WITH MOTOR RATED SWITCH NEXT TO HOOD. BENCH AT LOCATION SHOWN. WITH ROOF CURB.

ADDENDUM #1



**AE Group**  
Mechanical Engineers, Inc.  
838 East Front Street  
Ventura, California 93001  
(805) 653-1722 FAX: (805) 653-7260  
hugh@aegroupme.com

Gensler

5005 Figueroa Street  
Los Angeles CA 90071  
Tel: 213.327.3600  
Fax: 213.327.3601

Project VCC - Applied Science Building

Location 4667 Telegraph Rd. Ventura, CA 93003

Client VCCCD

By HAM

Date July 24, 2013

Checked HAM

Scale NONE

Sketch No.

SKM-001

Job No.

05.8010.000

# VENTURA COLLEGE - Applied Science Center

4667 Telegraph Rd, Ventura, CA 93003

500 S. Figueroa Street  
Los Angeles, CA 90071  
Tel: 213.327.3600  
Fax: 213.327.3601

## Gensler

**Penfield & Smith**  
Engineering • Surveying • Planning  
• Construction Management •  
1327 Del Norte Road, Suite 200, Conroir, CA 93010  
Phone: (805) 981-0706 Fax: (805) 981-0251

### DEMOLITION NOTES

- 1 REMOVE EXISTING ASPHALT PAVEMENT TO LIMITS SHOWN.
- 2 REMOVE EXISTING CONCRETE CURB TO LIMITS SHOWN. SAWCUT AND REMOVE EXISTING WALL TO LIMITS SHOWN. SAWCUT SHALL BE A CLEAN STRAIGHT EDGE. PAINT EXPOSED SURFACE TO MATCH EXISTING.
- 3 REMOVE EXISTING CONCRETE PAVEMENT TO LIMITS SHOWN.
- 4 REMOVE EXISTING CONCRETE MOW STRIP TO LIMITS SHOWN.
- 5 REMOVE EXISTING CONCRETE CURB AND GUTTER TO LIMITS SHOWN.
- 6 REMOVE EXISTING TREE.
- 7 REMOVE EXISTING RIBBON GUTTER TO LIMITS SHOWN. CLEAR AND GRUB LANDSCAPE AREA. COORDINATE WITH LANDSCAPE ARCHITECT.
- 8 SAWCUT EXISTING PAVEMENT.
- 9 RELOCATE EXISTING BUS BENCH SHELTER PER GRADING PLANS.
- 10 RELOCATE EXISTING SIGN PER GRADING PLAN.
- 11 EXISTING WALL/CURB TO REMAIN - PROTECT IN PLACE.
- 12 EXISTING TREE TO REMAIN - PROTECT IN PLACE.
- 13 EXISTING RIBBON GUTTER TO REMAIN - PROTECT IN PLACE.
- 14 EXISTING CURB TO REMAIN - PROTECT IN PLACE.
- 15 EXISTING SIGN TO REMAIN - PROTECT IN PLACE.
- 16 EXISTING RAMP AND HANDRAILS TO REMAIN - PROTECT IN PLACE.
- 17 EXISTING STEPS AND HANDRAILS TO REMAIN - PROTECT IN PLACE.
- 18 RELOCATE GATE AS SHOWN.
- 19 RELOCATE CONSTRUCTION FENCE (8' HIGH CHAINLINK WITH FABRIC SCREEN) AS SHOWN. SEE CONSTRUCTION FENCE NOTES, THIS SHEET.
- 20 EXISTING LANDSCAPING TO REMAIN - PROTECT IN PLACE.
- 21 EXISTING CONCRETE MOW STRIP TO REMAIN - PROTECT IN PLACE.
- 22 EXISTING UTILITY TO REMAIN - PROTECT IN PLACE.
- 23 CONTRACTOR TO REMOVE EXISTING CONCRETE PAVEMENT TO LIMITS SHOWN AT THE END OF THE CONSTRUCTION PHASE. COORDINATE TIMELINE WITH OWNER'S REPRESENTATIVE.
- 24 SAWCUT EXISTING PAVEMENT IN ACCORDANCE WITH DEMOLITION NOTE 25.
- 25 REMOVE EXISTING TEMPORARY INLET AND PIPE.
- 26 CLEAR AND GRUB NEEDS FROM PROJECT SITE.

### GENERAL DEMOLITION NOTES

1. DEMOLITION SHALL CONSIST OF FURNISHING ALL LABOR, MATERIALS AND EQUIPMENT NECESSARY TO REMOVE EXISTING STRUCTURES AND ALL OTHER OBJECTIONABLE MATERIAL FROM THE PROJECT SITE.
2. THE CONTRACTOR SHALL MAKE ARRANGEMENTS FOR THE REMOVAL OF MATERIAL FROM THE SITE AND ALL OBJECTIONABLE MATERIALS COVERED BY THESE PLANS. DISPOSAL OF MATERIALS SHALL BE DONE IN A SAFE AND LEGAL MANNER AND SHALL BE IN ACCORDANCE WITH ALL STATE AND LOCAL REGULATIONS.
3. THE CONTRACTOR SHALL CONTINUOUSLY CLEAN AND REMOVE DEMOLISHED MATERIALS FROM THE SITE EXCEPT WHERE SPECIFICALLY NOTED OTHERWISE. DO NOT ALLOW MATERIALS TO ACCUMULATE ON SITE.
4. EXISTING UNDERGROUND UTILITIES SHALL BE PROTECTED IN PLACE UNLESS OTHERWISE NOTED.
5. IT SHALL BE THE CONTRACTOR'S RESPONSIBILITY TO REPLACE IN-KIND ANY ITEMS DAMAGED DURING THE DEMOLITION PROCESS THAT ARE INTENDED TO REMAIN.
6. ALL EXISTING LANDSCAPE, EXCEPT TREES, INSIDE THE LIMITS OF WORK SHALL BE REMOVED, UNLESS OTHERWISE NOTED ON THE LANDSCAPE ARCHITECT'S PLANS. TREES TO BE REMOVED AS INDICATED ONLY.
7. ALL SURFACE FEATURES FOR EXISTING UNDERGROUND UTILITIES SHALL REMAIN AND BE ADJUSTED TO MATCH NEW FINISH GRADE - UNLESS OTHERWISE NOTED.
8. SAWCUT EXISTING PAVEMENT TO A CLEAN STRAIGHT EDGE.
9. ALL TREE ROOTS, ABANDONED IRRIGATION LINES, UTILITY SERVICES, SEPTIC TANKS AND SIMILAR MATERIALS SHALL BE REMOVED FROM THE SITE AND VOIDS CREATED THEREBY SHALL BE PROPERLY FILLED AND COMPACTED AS DIRECTED BY THE ENGINEER.
10. CONTRACTOR TO COORDINATE WITH DISTRICT STAFF FOR LOCATION OF EXISTING COMMUNICATION AND ELECTRICAL STUDS.
11. THE CONTRACTOR SHALL COMPLETELY REMOVE ANY EXISTING BUILDING FOUNDATION PILES ENCOUNTERED WITHIN THE PROPOSED BUILDING FOOTPRINT. IF ANY PILES ARE DISCOVERED OUTSIDE OF THE PROPOSED BUILDING FOOTPRINT THE CONTRACTOR SHALL CUT THE PILES 3-4 FEET BELOW THE PROPOSED FINISHED GROUND SURFACE.
12. CONTRACTOR SHALL MAINTAIN THE PROJECT SWPPP UNTIL FINAL LANDSCAPING IS INSTALLED.

### DEMOLITION LEGEND

(THIS LEGEND APPLIES TO THIS SHEET ONLY)

- LIMITS OF WORK/FENCELINE
- - - EXISTING FENCELINE TO BE RELOCATED
- SAW CUT
- EXISTING ASPHALT PAVEMENT TO BE REMOVED.
- EXISTING CONCRETE PAVEMENT TO BE REMOVED.
- EXISTING LANDSCAPE AREA TO BE CLEARED AND GRUBBED.
- EXISTING LANDSCAPING TO BE PROTECTED IN PLACE.
- EXISTING CONCRETE PAVEMENT TO BE REMOVED PER DEMOLITION NOTE 25

Seal/Signature



Project Name  
APPLIED SCIENCE CENTER

Project Number  
05.8010.000

Description  
DEMOLITION PLAN - HARDSCAPE/LANDSCAPE

Scale  
1"=20'

## C100-01

© 2006 Gensler

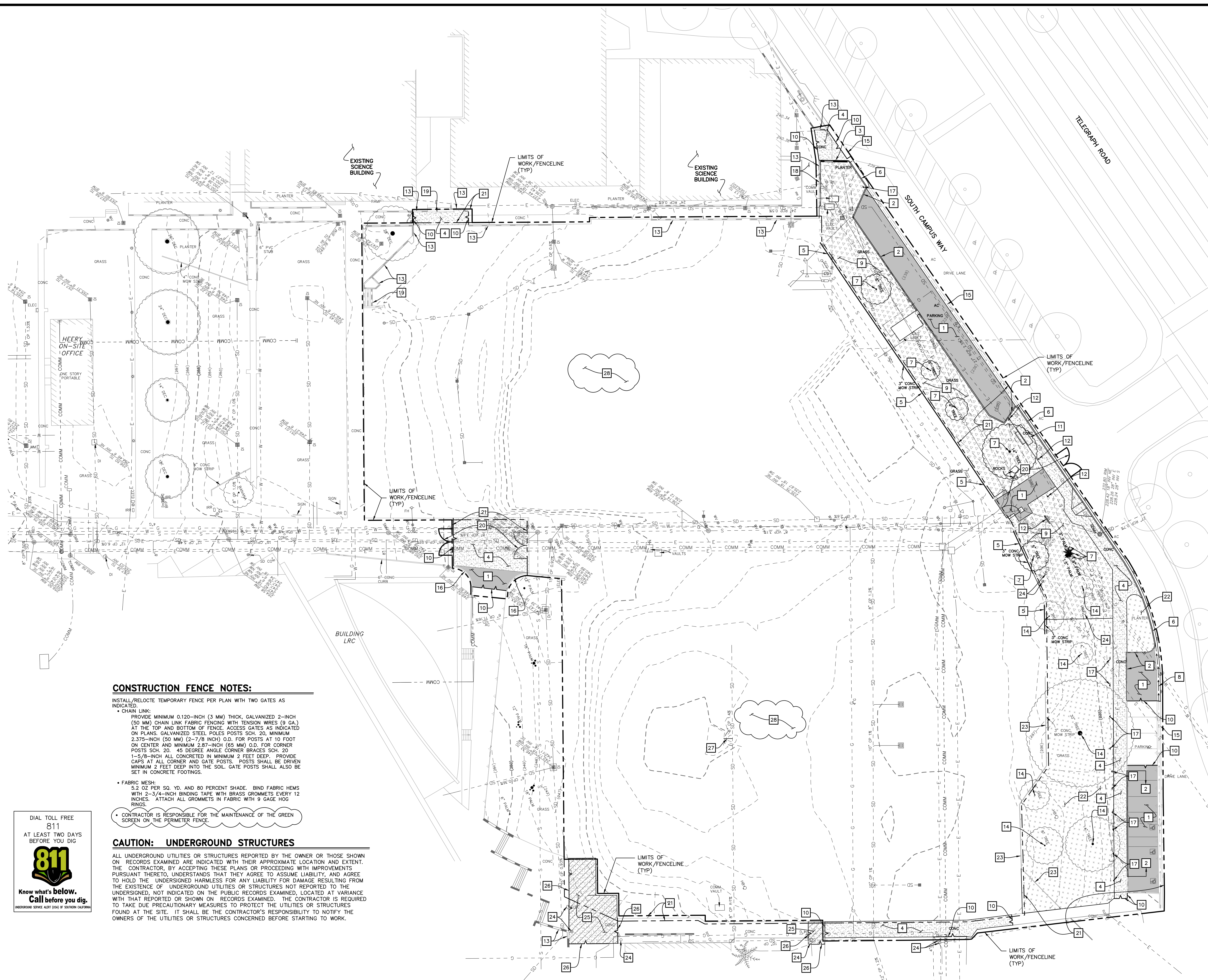

### CONSTRUCTION FENCE NOTES:

INSTALL/RELOCATE TEMPORARY FENCE PER PLAN WITH TWO GATES AS INDICATED.

- CHAIN LINK:  
PROVIDE MINIMUM 0.120-INCH (3 MM) THICK, GALVANIZED 2-INCH (50 MM) CHAIN LINK FABRIC FENCING WITH TENSION WIRES (9 GA.) AT THE TOP AND BOTTOM OF FENCE. ACCESS GATES AS INDICATED ON PLANS. GALVANIZED STEEL POLES POSTS SCH. 20, MINIMUM 2.375-INCH (50 MM) (2-7/8 INCH) O.D. FOR POSTS AT 10 FOOT ON CENTER AND MINIMUM 2.87-INCH (65 MM) O.D. FOR CORNER POSTS SCH. 20, 45 DEGREE ANGLE CORNER BRACES SCH. 20 1-5/8-INCH ALL CONCRETE IN MINIMUM 2 FEET DEEP. PROVIDE CAPS AT ALL CORNER AND GATE POSTS. POSTS SHALL BE DRIVEN MINIMUM 2 FEET DEEP INTO THE SOIL. GATE POSTS SHALL ALSO BE SET IN CONCRETE FOOTINGS.

- FABRIC MESH:  
5.2 OZ PER SQ. YD. AND 80 PERCENT SHADE. BIND FABRIC HEMS WITH 2-3/4-INCH BINDING TAPE WITH BRASS GROMMETS EVERY 12 INCHES. ATTACH ALL GROMMETS IN FABRIC WITH 9 GAGE HOG RINGS.

- CONTRACTOR IS RESPONSIBLE FOR THE MAINTENANCE OF THE GREEN SCREEN ON THE PERIMETER FENCE.

### CAUTION: UNDERGROUND STRUCTURES

ALL UNDERGROUND UTILITIES OR STRUCTURES REPORTED BY THE OWNER OR THOSE SHOWN ON RECORDS EXAMINED ARE INDICATED WITH THEIR APPROXIMATE LOCATION AND EXTENT. THE CONTRACTOR, BY ACCEPTING THESE PLANS OR PROCEEDING WITH IMPROVEMENTS PURSUANT THERETO, UNDERSTANDS THAT THEY AGREE TO ASSUME LIABILITY, AND AGREE TO HOLD THE UNDERSIGNED HARMLESS FOR ANY LIABILITY FOR DAMAGE RESULTING FROM THE EXISTENCE OF UNDERGROUND UTILITIES OR STRUCTURES NOT REPORTED TO THE UNDERSIGNED, NOT INDICATED ON THE PUBLIC RECORDS EXAMINED, LOCATED AT VARIANCE WITH THAT REPORTED OR SHOWN ON RECORDS EXAMINED. THE CONTRACTOR IS REQUIRED TO TAKE DUE PRECAUTIONARY MEASURES TO PROTECT THE UTILITIES OR STRUCTURES FOUND AT THE SITE. IT SHALL BE THE CONTRACTOR'S RESPONSIBILITY TO NOTIFY THE OWNERS OF THE UTILITIES OR STRUCTURES CONCERNED BEFORE STARTING TO WORK.

DIAL TOLL FREE  
811  
AT LEAST TWO DAYS  
BEFORE YOU DIG



**FUGITIVE DUST MITIGATION MEASURES**

- THE AREA DISTURBED BY CLEARING, GRADING, EARTH MOVING, OR EXCAVATION OPERATIONS SHALL BE MINIMIZED TO PREVENT EXCESSIVE AMOUNTS OF DUST.
- PRE-GRADING/EXCAVATION ACTIVITIES SHALL INCLUDE WATERING THE AREA TO BE GRADED OR EXCAVATED BEFORE COMMENCEMENT OF GRADING OR EXCAVATION OPERATIONS. APPLICATION OF WATER (PREFERABLE RECLAIMED, IF AVAILABLE) SHOULD PENETRATE SUFFICIENTLY TO MINIMIZE FUGITIVE DUST DURING GRADING ACTIVITIES.
- FUGITIVE DUST PRODUCED DURING GRADING, EXCAVATION, AND CONSTRUCTION ACTIVITIES SHALL BE CONTROLLED BY THE FOLLOWING ACTIVITIES:
  - ALL TRUCKS SHALL BE REQUIRED TO COVER THEIR LOADS AS REQUIRED BY CALIFORNIA VEHICLE CODE SECTION 23114.
  - ALL GRADED AND EXCAVATED MATERIAL, EXPOSED SOIL AREAS, AND ACTIVE PORTIONS OF THE CONSTRUCTION SITE, INCLUDING UNPAVED ON-SITE ROADWAYS, SHALL BE TREATED TO PREVENT FUGITIVE DUST. TREATMENT SHALL INCLUDE, BUT NOT NECESSARILY BE LIMITED TO, PERIODIC WATERING, APPLICATION OF ENVIRONMENTALLY SAFE SOIL STABILIZATION MATERIALS, AND/OR ROLL-COMPACTION AS APPROPRIATE. WATERING SHALL BE DONE AS OFTEN AS NECESSARY AND RECLAIMED WATER SHALL BE USED WHENEVER POSSIBLE.
- GRADED AND/OR EXCAVATED INACTIVE AREAS OF THE CONSTRUCTION SITE SHALL BE MONITORED AT LEAST WEEKLY FOR DUST STABILIZATION. SOIL STABILIZATION METHODS, SUCH AS WATER AND ROLL-COMPACTION, AND ENVIRONMENTALLY SAFE DUST CONTROL MATERIALS, SHALL BE PERIODICALLY APPLIED TO PORTIONS OF THE CONSTRUCTION SITE THAT ARE INACTIVE FOR OVER FOUR DAYS. IF NO FURTHER GRADING OR EXCAVATION OPERATIONS ARE PLANNED FOR THE AREA, THE AREA SHOULD BE SEEDED AND WATERED UNTIL GRASS GROWTH IS PERIODICALLY TREATED WITH ENVIRONMENTALLY SAFE DUST SUPPRESSANTS, TO PREVENT EXCESSIVE FUGITIVE DUST.
- DURING PERIODS OF HIGH WINDS (I.E., WIND SPEED SUFFICIENT TO CAUSE FUGITIVE DUST TO IMPACT ADJACENT PROPERTIES), ALL CLEARING, GRADING, EARTH MOVING, AND EXCAVATION OPERATIONS SHALL BE CURTAILED TO THE DEGREE NECESSARY TO PREVENT FUGITIVE DUST CREATED BY ON-SITE ACTIVITIES FROM BEING A NUISANCE OR HAZARD, EITHER OFF-SITE OR ON-SITE. THE SITE SUPERINTENDENT/SUPERVISOR SHALL USE HIS/HER DISCRETION IN CONJUNCTION WITH THE APCD IN DETERMINING WHEN WINDS ARE EXCESSIVE AND WHEN TO CURTAIL OPERATIONS.
- ADJACENT STREETS AND ROADS SHALL BE SWEEPED AT LEAST ONCE PER DAY, PREFERABLY AT THE END OF THE DAY, IF VISIBLE SOIL MATERIAL IS CARRIED OVER TO ADJACENT STREETS AND ROADS.
- PERSONNEL INVOLVED IN GRADING OPERATIONS, INCLUDING CONTRACTORS AND SUBCONTRACTORS, SHOULD BE ADVISED TO WEAR FACE MASK OR DUST MASK PROTECTION IN ACCORDANCE WITH CALIFORNIA DIVISION OF OCCUPATIONAL SAFETY AND HEALTH REGULATIONS.
- SHAKER PLATES SHALL BE INSTALLED AT ALL TRUCK EXITS FROM THE SITE.
- THE CABS OF GRADING AND CONSTRUCTION EQUIPMENT SHALL BE AIR-CONDITIONED.
- WORK CREWS SHALL WORK UPWIND FROM EXCAVATION SITES WHENEVER POSSIBLE.
- WHERE ACCEPTABLE TO THE DISTRICT, CONTROL WEED GROWTH BY MOWING INSTEAD OF DISKING, THEREBY LEAVING THE GROUND UNDISTURBED AND WITH A MULCH COVERING.

**CONSTRUCTION EQUIPMENT CONTROL MEASURES**

- CONTRACTOR SHALL MINIMIZE EQUIPMENT IDLING TIME THROUGHOUT CONSTRUCTION. ENGINES SHALL BE TURNED OFF IF IDLING WOULD BE FOR MORE THAN FIVE MINUTES.
- EQUIPMENT ENGINES SHALL BE MAINTAINED IN GOOD CONDITION AND IN PROPER TUNE AS PER MANUFACTURER'S SPECIFICATIONS.
- THE NUMBER OF PIECES OF EQUIPMENT OPERATING SIMULTANEOUSLY SHALL BE MINIMIZED.
- CONSTRUCTION CONTRACTORS SHALL USE ALTERNATIVELY FUELED CONSTRUCTION EQUIPMENT (SUCH AS COMPRESSED NATURAL GAS, LIQUEFIED NATURAL GAS, OR ELECTRIC) WHEN FEASIBLE.
- THE ENGINE SIZE OF CONSTRUCTION EQUIPMENT SHALL BE THE MINIMUM PRACTICAL SIZE.
- HEAVY-DUTY DIESEL-POWERED CONSTRUCTION EQUIPMENT MANUFACTURED AFTER 1996 (WITH FEDERALLY MANDATED CLEAN DIESEL ENGINES) SHALL BE UTILIZED WHEREVER FEASIBLE.
- DURING THE SMOG SEASON (MAY THROUGH OCTOBER), THE CONSTRUCTION PERIOD SHOULD BE LENGTHENED SO AS TO MINIMIZE THE NUMBER OF VEHICLES AND EQUIPMENT OPERATING AT THE SAME TIME.

**GRADING AND DRAINAGE GENERAL NOTES**

- ALL GRADING SHALL CONFORM TO THE LATEST EDITION OF THE STANDARD SPECIFICATIONS FOR PUBLIC WORKS CONSTRUCTION (SPPWC).
- CONTRACTOR SHALL ARRANGE FOR A PRECONSTRUCTION CONFERENCE 48 HOURS PRIOR TO THE BEGINNING OF CONSTRUCTION.
- ALL PERMITS NECESSARY PRIOR TO BEGINNING CONSTRUCTION SHALL BE OBTAINED BY THE CONTRACTOR.
- THROUGHOUT ALL PHASES OF CONSTRUCTION, INCLUDING SUSPENSION OF WORK, UNTIL FINAL ACCEPTANCE OF THE PROJECT, THE CONTRACTOR SHALL KEEP THE WORK SITE CLEAN AND FREE FROM RUBBISH AND DEBRIS. THE CONTRACTOR SHALL ALSO ABATE DUST NUISANCE BY CLEANING, SWEEPING AND SPRINKLING WITH WATER AND USING DUST FENCES OR OTHER METHODS THROUGHOUT THE CONSTRUCTION OPERATION.
- THE CONTRACTOR SHALL KEEP A STRICT RECORD OF ALL CHANGES AND SUBMIT THIS RECORD TO THE DISTRICT.
- ALL DAMAGE CAUSED TO PUBLIC STREETS, INCLUDING HAUL ROUTES, ALLEYS, SIDEWALKS, CURBS OR STREET FURNISHINGS, OR TO PRIVATE PROPERTY SHALL BE REPAIRED AT THE SOLE EXPENSE OF THE CONTRACTOR TO THE ENGINEER'S SATISFACTION.
- THE CONTRACTOR SHALL REMOVE AND REPLACE ANY EXISTING BROKEN OR DAMAGED SIDEWALK, CURB, GUTTER OR ASPHALT PAVING (PATCH, REPAIR OR OVERLAY) AS DIRECTED BY THE ENGINEER.
- AT LEAST TWO (2) WORKING DAYS BEFORE COMMENCING EXCAVATION, THE CONTRACTOR SHALL POTHOLE AND EXPOSE THE EXISTING UTILITIES AT ALL CROSSINGS AND AT THE POINT OF TIE-IN.
- ALL UNSUITABLE MATERIAL SHALL BE REMOVED AS REQUIRED BY THE ENGINEER FROM ALL AREAS TO RECEIVE COMPACTED FILL OR DRAINAGE STRUCTURES.
- ALL DELETERIOUS MATERIAL (E.G. - LUMBER, LOGS, BRUSH, RUBBISH, ETC.) SHALL BE REMOVED FROM ALL AREAS TO RECEIVE COMPACTED FILL AND HAULED TO A DUMP-SITE APPROVED BY THE ENGINEER.
- ALL SOIL OR ROCK MATERIALS DEEMED UNSUITABLE FOR PLACEMENT IN COMPACTED FILL SHALL BE REMOVED FROM THE SITE. ANY IMPORTED MATERIAL SHALL BE APPROVED BY THE ENGINEER PRIOR TO USE IN COMPACTED FILL.
- DURING THE RAINY SEASON (APPROXIMATELY OCTOBER THROUGH APRIL), THE CONTRACTOR SHALL BE RESPONSIBLE FOR PROVIDING STORM DAMAGE PREVENTION MEASURES OR EROSION CONTROL DEVICES AND/OR TO PERFORM CERTAIN GRADING OR PREVENT SOUNDING OR EXCESS RUNNING FROM FLOWING INTO PUBLIC STREETS OR ADJACENT PROPERTIES. IN THE EVENT OF SUCH AN OCCURRENCE, CLEANUP SHALL COMMENCE IMMEDIATELY.

- THE CONTRACTOR SHALL BE RESPONSIBLE FOR REMOVAL AND CLEANUP OF ANY SPILL ON PUBLIC STREETS DURING THE GRADING OPERATION, AS WELL AS REPAIR OF DAMAGE TO HAUL ROUTES AND EXISTING FACILITIES.
- REMOVE VEGETATION, IMPROVEMENTS, OR OBSTRUCTIONS INTERFERING WITH INSTALLATION OF NEW CONSTRUCTION. TRANSPORT AND LEGALLY DISPOSE OF OFF-SITE. REMOVAL INCLUDES STUMPS AND ROOTS. ENTIRE ROOT MAT WITHIN UPPER FEW TO SEVERAL INCHES OF GROUND SURFACE SHALL BE REMOVED AND WASTED OFF-SITE. CARE SHALL BE TAKEN SO AS NOT TO SCAR ANY AREA OF THE TREE'S BARK. CONTRACTOR SHALL UTILIZE THE BEST CONSTRUCTION METHOD TO MINIMIZE THE EROSION EFFECT FROM THE REMOVAL OF SITE VEGETATION.
- AREAS OUTSIDE "BUILDING AREA" TO RECEIVE PAVEMENT OR EXTERIOR FLATWORK SHALL BE OVEREXCAVATED TO A MINIMUM DEPTH OF 1 FOOT BELOW THE STRUCTURAL SECTION OF THE ON-GRADE IMPROVEMENT.
- EXCAVATION BOTTOMS SHALL BE OBSERVED BY THE GEOTECHNICAL REPRESENTATIVE PRIOR TO PLACEMENT OF FILL.
- THE CONTRACTOR SHALL PROTECT EXCAVATIONS BY METHODS NECESSARY TO PREVENT MOVEMENTS AND/OR LOOSENING OF SOILS PROVIDING LATERAL OR VERTICAL SUPPORT TO EXISTING IMPROVEMENTS.
- PROCESSING AND PLACEMENT OF FILL MATERIALS: ONSITE OR IMPORTED FILL SOIL SHALL BE PLACED AND COMPACTED AT A MOISTURE CONTENT BETWEEN 1 PERCENT AND 3 PERCENT OVER OPTIMUM MOISTURE CONTENT. EACH LAYER SHOULD BE SPREAD EVENLY AND SHALL BE THOROUGHLY BLADE-MIXED DURING SPREADING TO PROVIDE RELATIVE UNIFORMITY OF MATERIAL WITHIN EACH LAYER. BLOCKY OR CHANKY EARTH MATERIALS SHALL BE BROKEN DOWN TO PEA-SIZE OR FINER DURING PROCESSING AND PRIOR TO APPLICATION OF COMPACTIVE EFFORT. WHERE IMPORTED SOILS ARE PLACED ADJACENT TO ONSITE FILL MATERIAL, THE SOIL SHOULD BE MIXED TO PROVIDE RELATIVE UNIFORMITY OF MATERIAL WITHIN THE LAYER BEING PLACED.
- FILL SHALL BE SPREAD IN LIFTS NO THICKER THAN ABOUT 8 INCHES PRIOR TO BEING COMPACTED. FILL AND BACKFILL MATERIALS MAY NEED TO BE PLACED IN THINNER LIFTS TO ACHIEVE THE RECOMMENDED COMPACTION WITH THE EQUIPMENT BEING USED. LOOSE LIFT THICKNESS SHALL NOT EXCEED 6 INCHES WHEN USING HAND-OPERATED COMPACTION EQUIPMENT.
- FILL SOIL SHALL BE COMPACTED TO NOT LESS THAN THE 95% RELATIVE COMPACTION AS SPECIFIED IN THE GEOTECHNICAL STUDY AND IN ACCORDANCE WITH ASTM D1557 METHOD OF COMPACTION.
- AREAS OUTSIDE THE BUILDING AREA TO RECEIVE APPURTENANT STRUCTURES WITH FOOTINGS SHALL BE OVEREXCAVATED TO A DEPTH OF 3 FEET BELOW BOTTOM OF FOOTINGS AND TO A MINIMUM DISTANCE OF 5 FEET BEYOND THE EDGE OF FOOTINGS. COORDINATE WITH GEOTECHNICAL ENGINEER FOR LIMITS OF WORK ALREADY PERFORMED AS PART OF ROUGH GRADING.

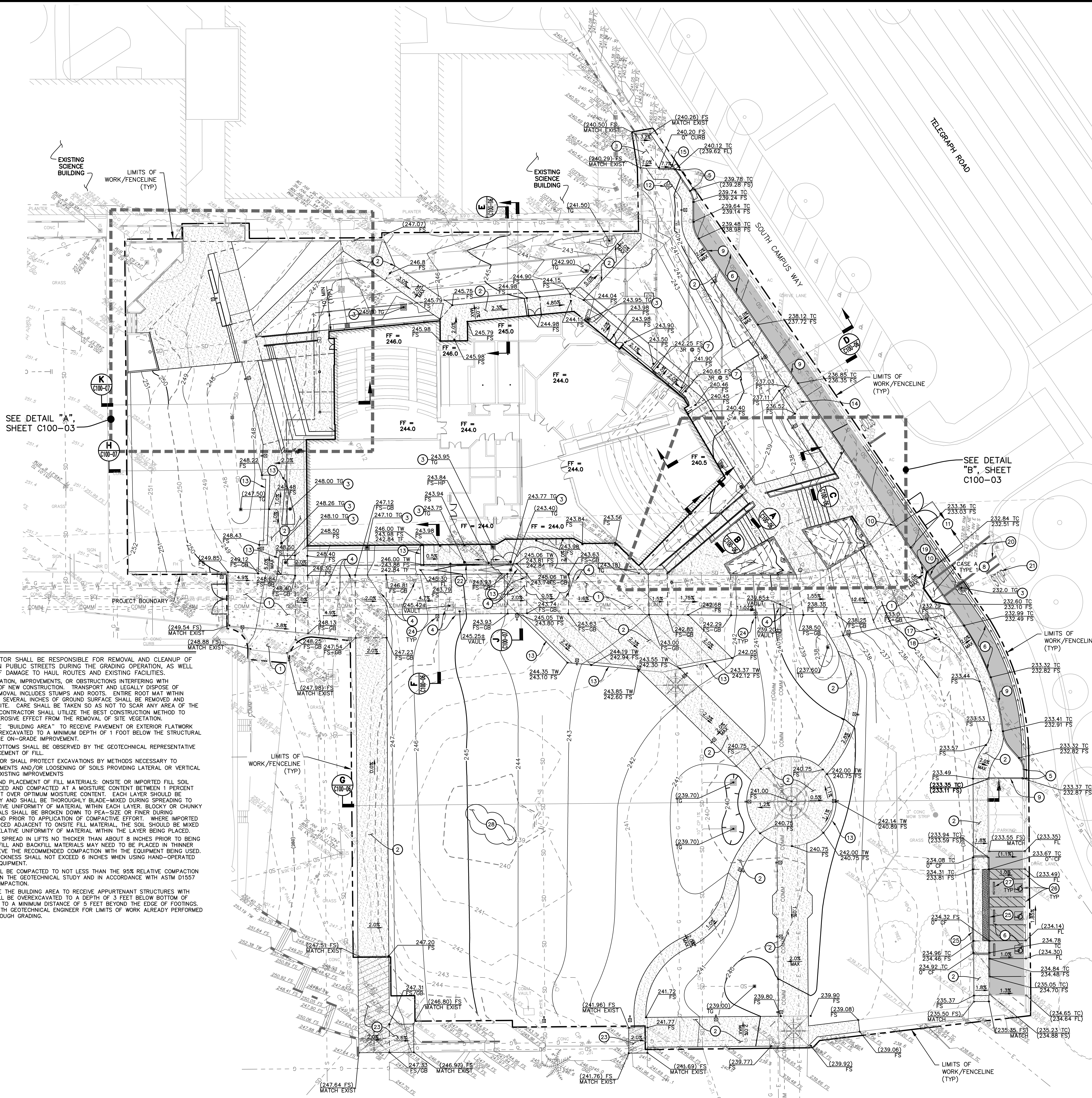

**CONSTRUCTION NOTES (THIS SHEET ONLY)**

- CONSTRUCT VEHICULAR ACCESS PAVEMENT PER DETAIL "D" SHEET C100-05. ADJUST ALL EXISTING UTILITY SURFACE FEATURES TO FINISH GRADE AS REQUIRED.
- CONSTRUCT 4" PCC PEDESTRIAN WALKWAY PER DETAIL "E" SHEET C100-05.
- CONSTRUCT DRAINAGE INLET PER UTILITY PLAN, SHEET C100-04.
- ADJUST EXISTING UTILITY SURFACE FEATURE TO GRADE.
- CONSTRUCT 6" CONCRETE CURB AND 24" GUTTER A2-150 PER SPPWC STANDARD PLAN 120-2 (SEE PROJECT SPECIFICATIONS APPENDIX). ADJUST TO MATCH EXISTING.
- CONSTRUCT 3" AC PAVING OVER 6" AGGREGATE BASE PER DETAIL "A", SHEET C100-05.
- CONSTRUCT REINFORCED CONCRETE STAIRS PER DETAIL "F", SHEET C100-05 AND PER SPPWC STANDARD PLAN 640-3. HANDRAILS PER SPPWC STANDARD PLAN 606-3 TYPE A, TOP RAIL TYPE 2 AS MODIFIED PER ARCHITECT'S DETAILS 18 & 20, SHEET A12.10 AS REQUIRED. SEE PROJECT SPECIFICATIONS APPENDIX.
- CONSTRUCT ADA RAMP PER SPPWC STANDARD PLAN 111-4. WIDTH TO BE 5'.
- CONSTRUCT 6" CONCRETE CURB TYPE A1-6 PER SPPWC STANDARD PLAN 120-2 (SEE PROJECT SPECIFICATIONS APPENDIX).
- TRANSITION FROM ROLLED CURB TO STANDARD CURB WITHIN 5'.
- CONSTRUCT 4" CONCRETE ROLLED CURB PER DETAIL "K", SHEET C100-05 AND PER SPPWC STANDARD PLAN 121-2. PAINT CURB RED.
- CONSTRUCT 3"x3"x4" CONCRETE PAD CENTERED ON PDC AND FLUSH WITH CONCRETE WALKWAY.
- CONSTRUCT CONCRETE SEAT WALL PER DETAIL "G" SHEET C100-05.
- INSTALL RELOCATED BUS STOP STRUCTURE AS SHOWN.
- TRANSITION FROM 6" TO 0" CURB AS SHOWN.
- TRANSITION FROM 6" CURB TO 0" CURB IN 12'.
- INSTALL RELOCATED PARKING SIGN.
- INSTALL RELOCATED CAMPUS DIRECTORY SIGN.
- INSTALL RELOCATED VEHICLE ACCESS SIGN.
- INSTALL 12" SOLID WHITE CROSSWALK (10" OC).
- INSTALL 12" WHITE STOP BAR AND LEGEND.
- CONSTRUCT LANDSCAPE WALL PER DETAIL "B" SHEET C100-05.
- CONTRACTOR TO CONSTRUCT PEDESTRIAN WALKWAY AT THE END OF CONSTRUCTION PHASE PER CONSTRUCTION NOTE 2. COORDINATE TIMELINE WITH OWNER'S REPRESENTATIVE.
- POLE LIGHT PER ELECTRICAL ENGINEER'S PLANS.
- CONSTRUCT CURB RAMP PER SPPWC STANDARD PLAN 111-4 TYPE 1 WITH RETAINING CURB BEHIND, MODIFIED AS SHOWN.
- INSTALL ADA SIGNAGE AND STRIPING PER STALL & SIGNAGE DETAILS 1, 2, 5 & 8, ARCHITECTURAL PLAN SHEET A00.08.
- INSTALL 4" PRECAST CONCRETE WHEEL STOP.
- PLACE EARTHWORK IN THIS AREA PER SPECIFICATIONS AND GEOTECHNICAL RECOMMENDATIONS.

**NOTES:**

- ALL DOOR LANDINGS TO BE 60" WIDE (MINIMUM) AND SLOPED AT 2% (MAXIMUM) IN ANY DIRECTION - TYPICAL.
- SAND BLAST EXISTING PAVEMENT MARKINGS AS REQUIRED PRIOR TO NEW SIGNING AND STRIPING.
- ALL STRIPING TO BE THERMOPLASTIC.
- GRADE SITE PER SOILS ENGINEER RECOMMENDATIONS TO ROUGH GRADE SURFACE SHOWN.
- CONTRACTOR SHALL MAINTAIN THE PROJECT SWPPP UNTIL FINAL LANDSCAPING IS INSTALLED.

**LEGEND:**

- VEHICULAR PAVING
- PEDESTRIAN PAVING
- AC PAVING
- GRAVEL LANDSCAPE AREA
- PEDESTRIAN PAVING PER CONSTRUCTION NOTE 23
- LIMITS OF WORK/FENCELINE
- OVER EXCAVATION PERFORMED UNDER SEPARATE CONTRACT

**VENTURA COLLEGE - Applied Science Center**  
 4667 Telegraph Rd, Ventura, CA 93003

**Gensler**  
 500 S. Figueroa Street  
 Los Angeles, CA 90071  
 Tel: 213.327.3600  
 Fax: 213.327.3601

**Penfield & Smith**  
 Engineering • Surveying • Planning  
 • Construction Management •  
 1327 Del Norte Road, Suite 200, Camarillo, CA 93010  
 Phone: (805) 981-0706 Fax: (805) 981-0251

05/13/2013 DSA BACKCHECK SET

Issue	Date & Issue Description	By	Check
	JULY 25, 2013	ADDENDUM NO. 1	

**NOTES:**

- ALL DOOR LANDINGS TO BE 60" WIDE (MINIMUM) AND SLOPED AT 2% (MAXIMUM) IN ANY DIRECTION - TYPICAL.
- SAND BLAST EXISTING PAVEMENT MARKINGS AS REQUIRED PRIOR TO NEW SIGNING AND STRIPING.
- ALL STRIPING TO BE THERMOPLASTIC.
- GRADE SITE PER SOILS ENGINEER RECOMMENDATIONS TO ROUGH GRADE SURFACE SHOWN.
- CONTRACTOR SHALL MAINTAIN THE PROJECT SWPPP UNTIL FINAL LANDSCAPING IS INSTALLED.

Seal/Signature

Project Name  
 APPLIED SCIENCE CENTER

Project Number  
 05.8010.000

Description  
 GRADING PLAN

Scale  
 1"=20'

**C100-02**

© 2006 Gensler

**GRADING PLAN**  
 SCALE: 1"=20'

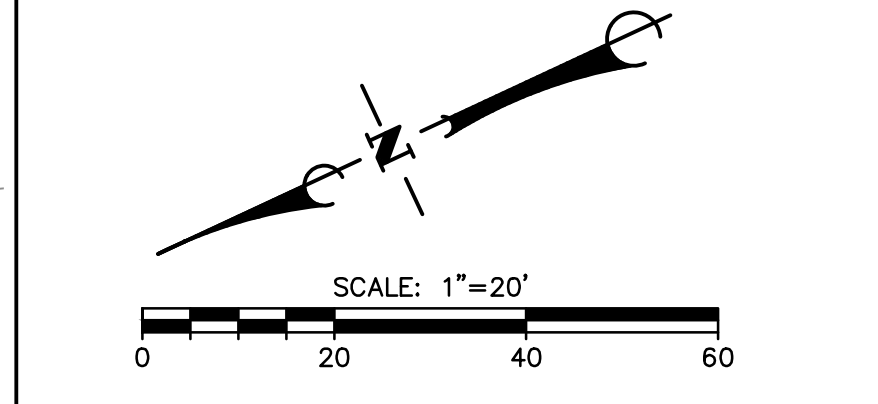



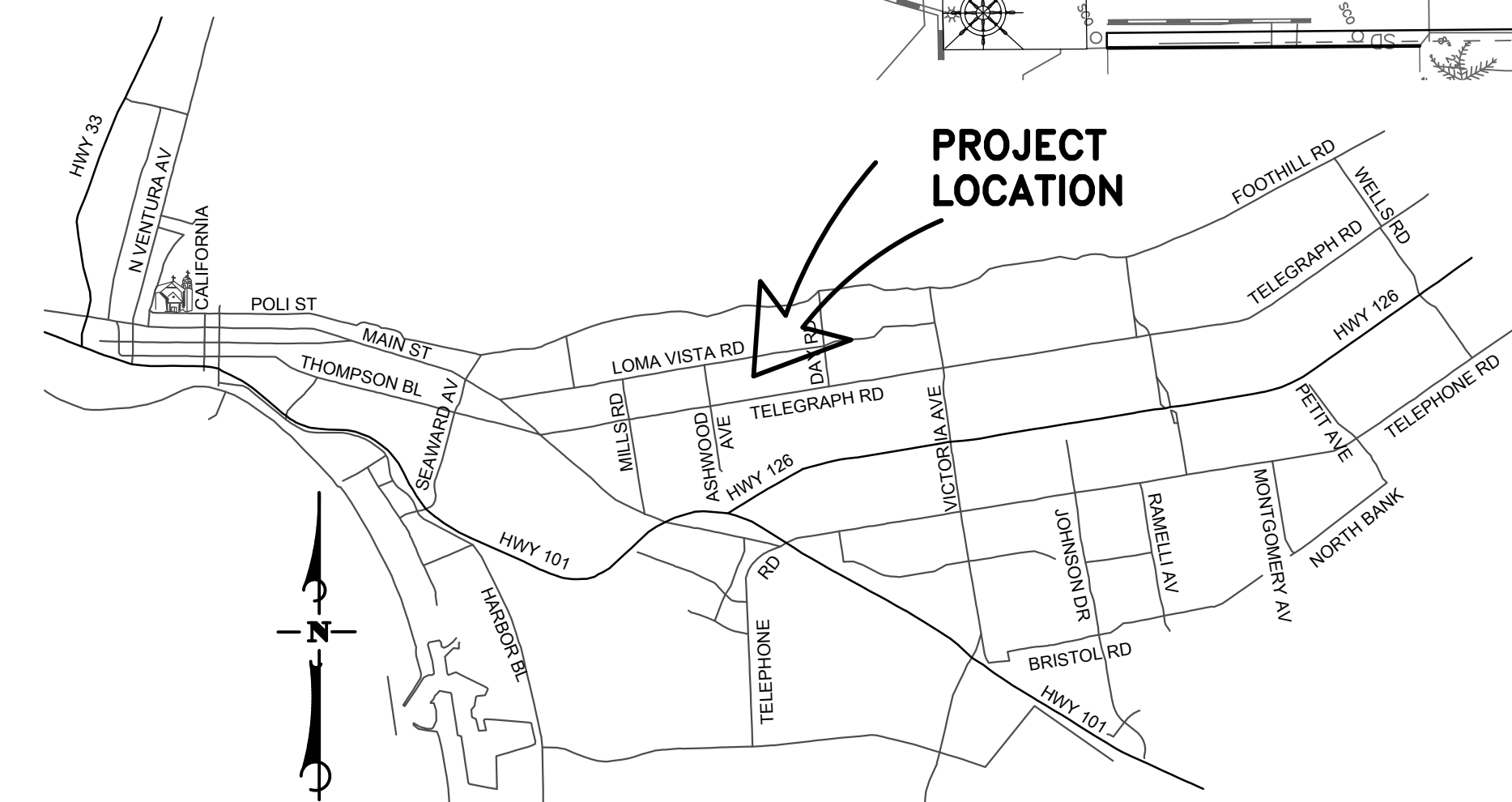
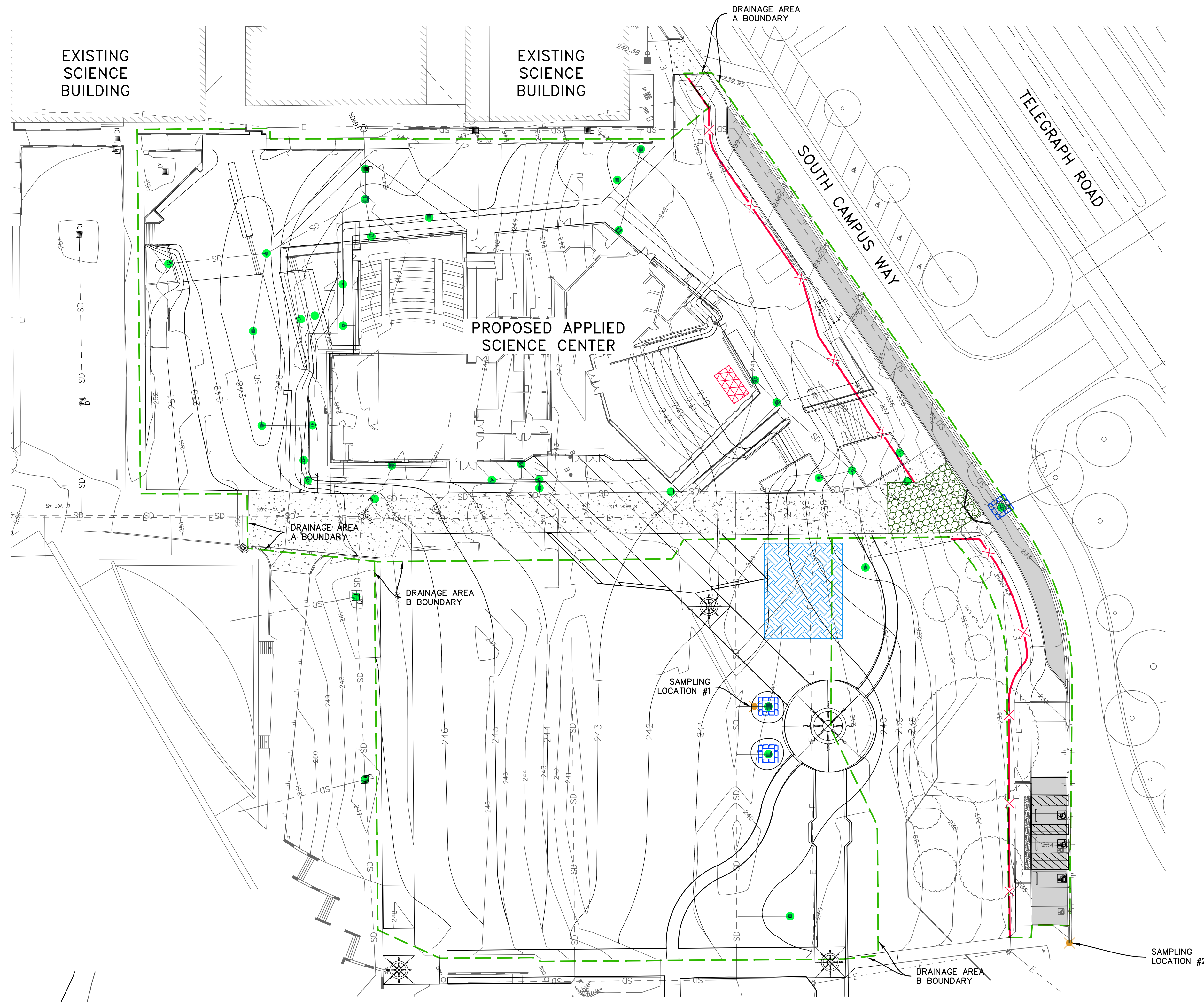

**LEGEND**

	INDICATES CONSTRUCTION ENTRANCE TO BE PROTECTED PER BMPs TC-1, TYPE 2, AND TC-3.
	INDICATES AREA ON SITE TO BE USED FOR MATERIALS STORAGE, WASHOUT AREA, AND VEHICLE STORAGE PER BMPs WM-1, WM-3, WM-8, NS-9, AND NS-10.
	INDICATES INLET PROTECTION PER BMP SE-10, TYPE 5.
	INDICATED INLET PROTECTION PER BMP SE-10, TYPE 3.
	INDICATES SILT FENCE PROTECTION PER BMP SE-1.
	INDICATES GRAVEL BAG PROTECTION PER BMP SE-6.
	INDICATES PROPOSED DRAINAGE AREA.
	INDICATES SAMPLING LOCATIONS PER SECTION 7.7.1.2 OF THE SWPPP.
	INDICATES SEDIMENT TRAP PER BMP SE-3.

- BEST MANAGEMENT PRACTICES (BMP'S) GENERAL NOTES**
- BMP'S REFERENCED ARE FROM THE CALIFORNIA STORM WATER BEST MANAGEMENT PRACTICE HANDBOOKS (CONSTRUCTION), NOVEMBER 2009.
  - CONTRACTOR TO IMPLEMENT STREET SWEEPING AND VACUUMING, BMP SE-7, AS DESCRIBED IN THE SWPPP DOCUMENTS AND TO THE SATISFACTION OF THE RESIDENT INSPECTOR AS CONDITIONS WARRANT.
  - BMP'S NOT INDICATED ON THIS PLAN MAY BE IMPLEMENTED AS DEEMED NECESSARY BY THE RESIDENT INSPECTOR.
  - THE LOCATION AND DESIGN OF ALL EROSION CONTROL MEASURES SHOWN ON THESE PLANS ARE TENTATIVE ONLY AND SUBJECT TO REVISIONS AS DETERMINED BY THE RESIDENT INSPECTOR OR THE CITY ENGINEER. ACTUAL EROSION CONTROL SHALL BE INSTALLED TO THE SATISFACTION OF THE RESIDENT INSPECTOR AS CONDITIONS WARRANT. SILT, DEBRIS AND MUD SHALL BE PROMPTLY REMOVED FROM ALL EROSION CONTROL STRUCTURES AFTER EACH RAIN TO THE SATISFACTION OF THE RESIDENT INSPECTOR. THE CITY MAY CONDUCT REGULAR SITE INSPECTIONS TO ASSESS CHANGING CONDITIONS AND DETERMINE THE NECESSITY OF ADDITIONAL EROSION CONTROL MEASURES.

- NPDES GENERAL NOTES**
- CONSTRUCTION SITES SHALL BE MAINTAINED IN SUCH A CONDITION THAT AN ANTICIPATED STORM OR CONSTRUCTION ACTIVITY DOES NOT CARRY WASTES OR POLLUTANTS OFF THE SITE.
  - DISCHARGES OF MATERIALS OTHER THAN STORM WATER ARE ALLOWED ONLY WHEN NECESSARY FOR PERFORMANCE AND COMPLETION OF CONSTRUCTION PRACTICES AND WHERE THEY DO NOT CAUSE OR CONTRIBUTE TO A VIOLATION OF ANY WATER QUALITY STANDARD; CAUSE OR THREATEN TO CAUSE POLLUTION, CONTAMINATION, OR NUISANCE; OR CONTAIN A HAZARDOUS SUBSTANCE IN A QUANTITY REPORTABLE UNDER FEDERAL REGULATIONS 40 CFR PARTS 117 & 302.
  - POTENTIAL POLLUTANTS INCLUDE BUT ARE NOT LIMITED TO: SOLID OR LIQUID CHEMICAL SPILLS; WASTES FROM PAINTS, STAINS, SEALANTS, GLUES, LIMES, PESTICIDES, HERBICIDES, WOOD PRESERVATIVES, AND SOLVENTS; ASBESTOS; FIBERS, PAINT FLAKES OR STUCCO FRAGMENTS; FUELS, OILS, LUBRICANTS, AND HYDRAULIC, RADIATOR OR BATTERY FLUIDS; FERTILIZERS, VEHICLE/EQUIPMENT WASH WATER AND CONCRETE WASH WATER; CONCRETE, DETERGENT OR FLOATABLE WASTES; WASTES FROM ANY ENGINE/EQUIPMENT STEAM CLEANING OR CHEMICAL DEGREASING; AND SUPERCHLORINATED POTABLE WATER LINE FLUSHINGS.
  - DURING CONSTRUCTION, DISPOSAL OF SUCH MATERIALS SHOULD OCCUR IN A SPECIFIED AND CONTROLLED TEMPORARY AREA ON-SITE, PHYSICALLY SEPARATED FROM POTENTIAL STORM WATER RUN-OFF, WITH ULTIMATE DISPOSAL IN ACCORDANCE WITH LOCAL, STATE, AND FEDERAL REQUIREMENTS.
  - DEWATERING OF CONTAMINATED GROUNDWATER, OR DISCHARGING CONTAMINATED SOILS VIA SURFACE EROSION, IS PROHIBITED. DEWATERING OF NON-CONTAMINATED GROUNDWATER REQUIRES A NATIONAL POLLUTANT DISCHARGE ELIMINATION SYSTEM (NPDES) PERMIT FROM THE RESPECTIVE STATE OF WATER QUALITY CONTROL BOARD.
  - ALL ACTIVITIES WILL CONFORM TO VENTURA COUNTYWIDE STORM WATER QUALITY MANAGEMENT PROGRAM NPDES PERMIT NO. CAS004002 AND CALIFORNIA STORM WATER BEST MANAGEMENT PRACTICES HANDBOOK.
  - THE PROJECT CONSERVATION PLANS WILL INCORPORATE BEST MANAGEMENT PRACTICE (BMP'S) APPLICABLE TO THE DEVELOPMENT TO THE REVIEW AND SATISFACTION OF THE CITY ENGINEER. BMP'S FOR THIS PROJECT WILL INCLUDE (BUT ARE NOT LIMITED TO THE FOLLOWING):
    - ALL STORM DRAIN INLETS SHALL BE LABELED "DON'T DUMP - DRAINS TO OCEAN"
    - ALL AREAS SHALL BE MAINTAINED FREE OF LITTER AND DEBRIS TO PREVENT THE ACCUMULATION OF LITTER AND DEBRIS FROM ENTERING THE STORM DRAIN OR BEING BLOWN OFF THE SITE. NO CLEANING AGENT OR OTHER POLLUTANT SHALL BE DISCHARGED INTO THE STORM DRAIN SYSTEM. IF ANY CLEANING AGENT OR DEGREASER IS USED, WASH WATER SHALL NOT BE DISCHARGED TO THE STORM DRAIN OR DISCARDED ON SITE. WASH WATER SHALL BE COLLECTED BY VACUUM OR OTHER SUCH APPROPRIATE METHOD AND DISCARDED AT AN APPROVED DISPOSAL LOCATION.
    - ALL STORM DRAINS SHALL BE CLEANED, USING APPROPRIATE METHODS AND TO THE SATISFACTION OF THE CITY ENGINEER PRIOR TO ACCEPTANCE.
  - THE DEVELOPER SHALL EMPLOY A FULL-TIME SUPERINTENDENT FOR NPDES COMPLIANCE. THE NPDES SUPERINTENDENT SHALL BE PRESENT, ON THE PROJECT SITE MONDAY THROUGH FRIDAY AND ON ALL OTHER DAYS WHEN THE PROBABILITY OF RAIN IS 40% OR HIGHER AND PRIOR TO THE START OF AND DURING ALL GRADING OR CLEARING OPERATIONS UNTIL THE RELEASE OF GRADING BONDS. THE NPDES SUPERINTENDENT SHALL HAVE FULL AUTHORITY TO HIRE PERSONNEL, BIND THE DEVELOPER IN CONTRACTS, RENT EQUIPMENT AND PURCHASE MATERIALS TO THE EXTENT NEEDED TO EFFECTUATE BEST MANAGEMENT PRACTICES. IN ADDITION, THE NPDES SUPERINTENDENT SHALL BE EMPLOYED TO ASSUME NPDES COMPLIANCE DURING THE CONSTRUCTION OF STREETS, STORM DRAINAGE SYSTEMS, ALL UTILITIES, BUILDINGS AND FINAL LANDSCAPING OF THE SITE.
  - THE FOLLOWING BMP'S FROM THE CALIFORNIA STORMWATER QUALITY ASSOCIATION - STORMWATER BEST MANAGEMENT PRACTICE HANDBOOK (CONSTRUCTION), NOVEMBER 2009, MUST BE IMPLEMENTED FOR ALL CONSTRUCTION ACTIVITIES AS APPLICABLE:

<b>EROSION CONTROL</b>	<b>SEDIMENT CONTROL</b>
EC1 - SCHEDULING	SE1 - SILT FENCE
EC2 - PRESERVATION OF EXISTING VEGETATION	SE2 - GRAVEL BAG BERM
	SE7 - STREET SWEEPING AND VACUUMING
<b>TRACKING CONTROL</b>	SE8 - SANDBAG BARRIER
TC1 - STABILIZED CONSTRUCTION ENTRANCE/EXIT	SE10 - STORM DRAIN INLET PROTECTION
TC3 - ENTRANCE/EXIT TIRE WASH	<b>WIND EROSION CONTROL</b>
	WE1 - WIND EROSION CONTROLS
<b>NON-STORMWATER MANAGEMENT</b>	<b>WASTE MANAGEMENT</b>
NS1 - WATER CONSERVATION PRACTICES	WM1 - MATERIAL DELIVERY AND STORAGE
NS2 - DEWATERING OPERATIONS	WM3 - STOCKPILE MANAGEMENT
NS3 - PAVING AND GRINDING OPERATIONS	WM4 - SPILL PREVENTION AND CONTROL
NS7 - POTABLE WATER/IRRIGATION	WM5 - SOLID WASTE MANAGEMENT
NS8 - VEHICLE AND EQUIPMENT CLEANING	WM8 - CONCRETE WASTE MANAGEMENT
NS12 - CONCRETE CURING	WM9 - SANITARY/SEPTIC WASTE MANAGEMENT
NS13 - CONCRETE FINISHING	

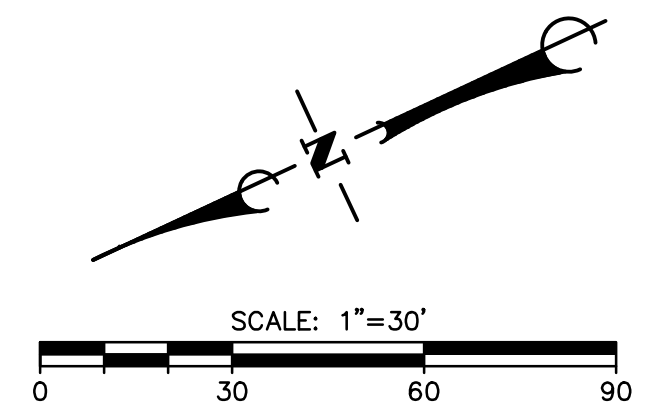

36-EXB SAVE DATE: 10/20/2011 4:35:46 PM PLOT BY: Greg Musser PLOT DATE: 7/8/2013 10:31:58 AM PLOT SCALE: 1:1

DRAWING: \\arcad\work\19965\erob\1\19965.ecp.dwg

July 22, 2013  
Project No. 1003.028

**PROJECT MEMORANDUM**

**To:** Rich Magill  
**From:** Carole Wockner, P.E.  
**Subject:** **Response to Pre-Bid RFI No. 002**  
**Project:** **Applied Sciences Lecture Hall, Ventura College, Ventura, California**

---

RFI No. 2 consists of the following inquiry by GRD Construction:

*We were provided with a Geotechnical Study by Geotechniques dated July 2011. Section 6.0 – Recommendations refers to removal of existing underground utilities, building foundations, piles, etc. and to the overexcavation, recompaction and construction of the building pad. This work has already been done. Is there a soils report, or an addendum to the soils report, that addresses the recommendations for the earthwork required for the site in it's current state. I believe at the job-walk Carole Wockner indicated that there was a report with recommendations for the clear & grub & earthwork now required.*

The building pad which includes that area to a distance of 10 feet beyond foundations has been overexcavated to a depth of 5 feet below proposed subgrade elevation. Additionally, piles from the former buildings have been removed in the building pad area and to a distance of about 10 feet beyond, and piles outside that area have been cut off to a depth of about 5 feet below proposed subgrade. Earthwork for this bid includes, but is not limited to, the following:

1. Removal of all vegetation and roots/root mat by stripping surface and wasting stripped organics off-site.
2. Compacting soil materials disturbed from stripping vegetation or construction activities in improvement areas to a minimum of 95 percent of the maximum dry density. Soil shall be moisture conditioned and processed prior to compaction in accordance with Section 6.1.8 of Geotechnical Study.
3. Preparation of subgrade below proposed on-grade exterior concrete, asphalt concrete, appurtenant structures, including but not limited to site retaining walls, and foundations in accordance with Sections 6.1.4, 6.1.5, and 6.1.8 of Geotechnical Study and Section 31 20 00, paragraph 3.01 B.9. of Specifications. Materials in those areas and trench bedding, pipe zone and backfill, shall be compacted of to a minimum of 95% of the maximum dry density.
4. Placement and compaction to a minimum of 95 percent relative compaction of retaining wall backfill (Section 6.4) and interior floor slab subgrade (Section 6.3.2.4) , consisting of capillary break, vapor barrier, and clean sand.